



Fresh Air Ventilation and Heat Exchange unit SAF-E7

Model No.

- SAF150E7
- SAF250E7
- SAF350E7
- SAF500E7
- SAF800E7
- SAF1000E7



Energy Performance of Building Directive - EPBD

EPBD limit the amount of electrical/gas power to be used to provide heating or cooling in commercial buildings. Therefore the building designer needs to select energy efficient heating/cooling equipment, and to minimise energy losses through ventilation systems.

The SAF recovers heat energy which would otherwise be exhausted to atmosphere, and uses this energy to warm the air entering the building. The reverse happens in warmer climates, where the exhausted cool air is used to partially cool the incoming air.

Capturing this waste energy, means the heating/ cooling requirements of the building are reduced, so smaller size plant can be selected, savings can be made in long term energy consumption, and carbon emissions are reduced.

Increased external static pressure at UHI air flow

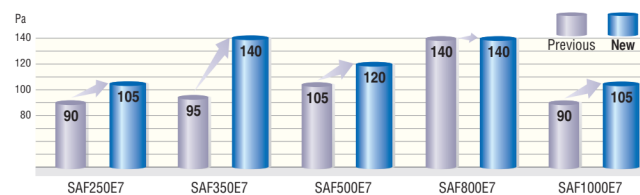

Switch box (option)



Remote control

The following functions are newly available.

- ON/OFF Timer – The hour and minute of timer on/off can be set.
- Filter Sign – Announces the due time for cleaning the air filter.

Specifications

Item	Model	SAF150E7	SAF250E7	SAF350E7	SAF500E7	SAF800E7	SAF1000E7		
Power source		1 Phase 220-240V, 50Hz							
Exterior dimensions Height x Width x Depth	mm	270x970x467	270x882x599	317x1050x804	317x1090x904	388x1322x884	388x1322x1134		
Exterior appearance		Galvanized steel sheet							
Power input	W	92-107	108-123	178-185	204-225	360-378	416-432		
Running current	A	0.42-0.45	0.49-0.51	0.81-0.77	0.93-0.94	1.64-1.58	1.89-1.80		
Capacity	UHi	Enthalpy exchange efficiency	Cooling	63	63	66	62	65	65
		Enthalpy exchange efficiency	Heating	70	70	69	67	71	71
		Temperature exchange efficiency		75					
	Hi	Enthalpy exchange efficiency	Cooling	63	63	66	62	65	65
		Enthalpy exchange efficiency	Heating	70	70	69	67	71	71
		Temperature exchange efficiency		75					
	Lo	Enthalpy exchange efficiency	Cooling	66	65	71	64	68	70
		Enthalpy exchange efficiency	Heating	73	72	73	69	74	76
		Temperature exchange efficiency		77	77	78	76	76	79
Motor & Q'ty	W	10 x 2	20 x 2	40 x 2	70 x 2	180 x 2	180 x 2		
Air handling equipment Fan type & Q'ty		Sirocco fan x 2							
Air flow	UHi	150	250	350	500	800	1000		
	Hi	150	250	350	500	800	1000		
	Lo	120	190	240	440	630	700		
External static pressure	UHi	80	105	140	120	140	105		
	Hi	70	95	60	60	110	80		
	Lo	25	45	45	35	55	75		
Net weight	kg	25	29	49	57	71	83		
Remote control		Included							
Air filter	Supply air Exhaust air	Protection for element (Washable) PS400							

Structure (SAF800E7)

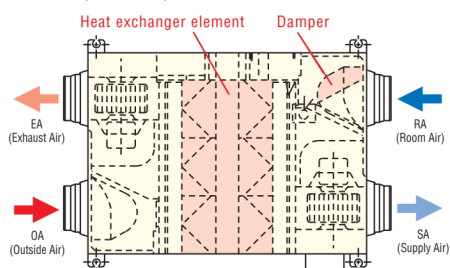

Principle of operation (simple ventilation)

FREE COOLING

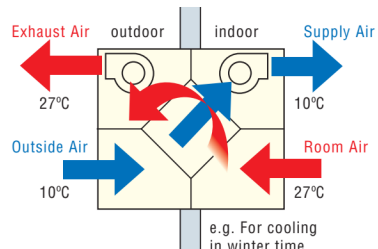

Principle of operation (heat exchanging)

ENERGY RECOVERY

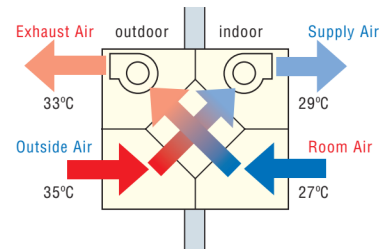

Dimensions

All measurements in mm.

SAF150E7, SAF250E7, SAF350E7, SAF500E7

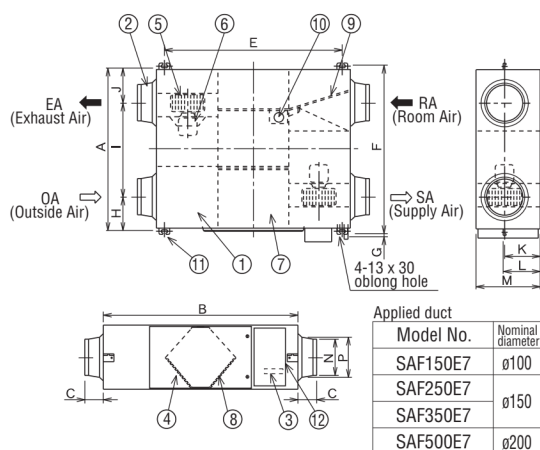

SAF800E7, SAF1000E7

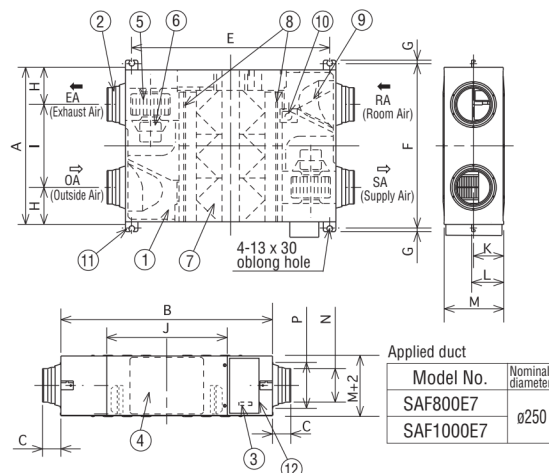

Dimension table

Model	A	B	C	E	F	G	H	I	J	K	L	M	N	P
SAF150E7	467	970	49	810	525	19	82	303	82	135	159	270	ø98	ø110
SAF250E7	599	882	95	655			142	315	142					ø144
SAF350E7	804	1050	70	978	860		112	580	112	159	182	317		ø164
SAF500E7	904	1090		1018	960		132	640	132				ø194	ø210

Dimension table

Model	A	B	C	E	F	G	H	I	J	K	L	M	N	P
SAF800E7	884	1322	85	1250	940	19	228	428	612	194	218	388	ø242	ø258
SAF1000E7	1134				1190			678						

NO.	Name	Qt'y
①	Frame	1
②	Adaptor	4
③	Terminal board	1
④	Inspection Cover	1
⑤	Fan	2 ※
⑥	Motor	2 ※
⑦	Heat Exchange Element	
	SAF150E7	1
	SAF250E7	1
	SAF350E7	2
	SAF500E7	2
	SAF800E7	3
	SAF1000E7	4
⑧	Filter	2
⑨	Damper	1
⑩	Damper Motor	1
⑪	Suspension fitting	4
⑫	Electrical components box	1

※Model SAF350E7, SAF500E7 have different fan and motor locations.

Installation reference

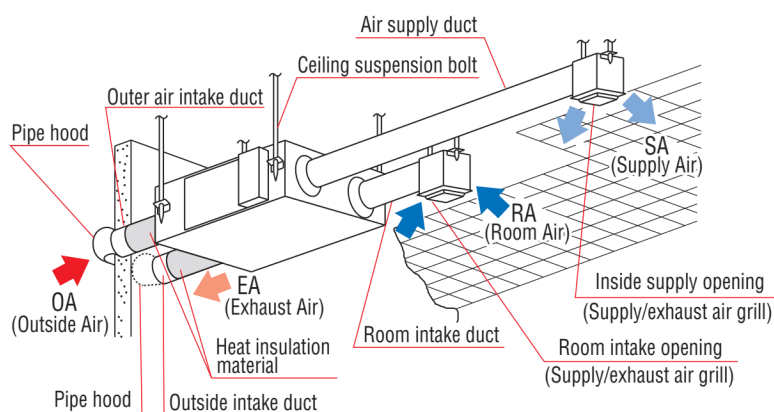

Note: An inspection port is needed for cleaning the heat exchanger and filter 1 or 2 times a year.