

marstair

A Division of **TEV** Ltd

INSTALLATION & TECHNICAL MANUAL



MARSTAIR REFRIGERATION CONDENSING UNITS (MRC+)

INDEX

<u>CONTENTS</u>	<u>PAGE</u>
DIMENSIONS & WEIGHTS (packed & unpacked) & SPECIFICATION.	3
PERFORMANCE DATA.	4-11
MOUNTING, DIMENSIONS & WEIGHTS.	12-13
PIPEWORK.	13-14
ELECTRICAL & FUSES.	14-16
REFRIGERANT.	17-18
END OF LIFE REQUIRMENTS.	19
ECO DESIGN INFORMATION TABLES.	20-27
COMPONENT IDENTIFICATION MRC+.	28-29

NOTE

IF MECHANICAL PUMP DOWN OPERATION IS REQUIRED CONNECT A LINK WIRE
BETWEEN TERMINALS L1 & 3.
IF THIS LINK IS USED THEN TERMINAL 5 CAN NOT BE USED AS AN ALARM FACILITY

1. TEV LTD recommend that personnel working on this equipment be skilled and fully conversant with the appropriate Refrigeration and Electrical practices and have sound knowledge of current Industrial Safe Working practices.
2. These units are supplied with a holding charge of oxygen free nitrogen and polyolester oil. Do not mix oils or refrigerants.
3. These units when installed contain live electrical components, moving parts and refrigerant under pressure. Always site out of reach of children and protect from vandalism.
4. The data plate only gives information for the outdoor unit. For system details add input power and current of indoor and outdoor unit, including any heater load.
5. FUSES - for recommended fuse size see page 12.
6. The refrigerant used should be identified by locating a refrigerant label on the unit case

GENERAL

DIMENSIONS AND WEIGHTS

UNPACKED

MRC+ CONDENSING UNITS

MODEL	15	20	30	40	45	50	60	80	90	100	130	150	165	180
HEIGHT	620	620	620	620	720	720	720	720	820	820	1080	1080	1080	1275
WIDTH	900	900	900	900	1000	1000	1000	1000	1000	1000	1000	1000	1000	1100
DEPTH	300	300	300	300	350	350	350	350	350	350	425	425	425	425
1 Ph kg	46	47	48	53	61	64	65	66	76	81	-	103	-	-
3 Ph kg	-	-	48	53	-	64	65	66	76	81	101	103	103	118

PACKED

MRC+ CONDENSING UNITS

MODEL	15	20	30	40	45	50	60	80	90	100	130	150	165	180
HEIGHT	620	620	620	620	720	720	720	720	820	820	1080	1080	1080	1280
WIDTH	980	980	980	980	1090	1090	1090	1090	1090	1090	1090	1090	1090	1215
DEPTH	340	340	340	340	390	390	390	390	390	390	465	465	465	465
1 Ph kg	48	49	50	55	63	66	67	68	78	85	-	107	-	-
3 Ph kg	-	-	50	55	-	66	67	68	78	85	105	107	107	123

SPECIFICATION DETAILS

MRC+		15	20	30	40	45	50	60	80	90	100	130	150	165	180	
Nominal cooling capacity (-10°C evaporating temp & 32°C ambient temp) R404A	kW	1.1	1.4	2.0	2.9	2.9	3.9	4.6	5.5	6.4	7.1	-	8.8	-	-	
	1Ph 3Ph	-	-	2.0	2.9	2.9	3.9	4.6	5.5	6.4	7.1	8.1	8.8	10.5	11.6	
Operating weight kg	1Ph	46	47	48	53	61	64	65	66	76	81	-	103	-	-	
	3Ph	-	-	48	53	-	64	65	66	76	81	101	103	103	118	
1 Ph (230V 50Hz) compressor load only (at nominal cooling capacity)																
Power (nominal)	kW	0.82	1.12	1.42	2.07	1.43	2.03	2.26	2.61	3.03	3.92	-	4.52	-	-	
Starting current LRA	A	23	28	36	50	35	58	61	76	110	114	-	142	-	-	
Nominal current FLA	A	5.9	6.9	8.1	10.2	10.0	8.9	9.8	11.5	16.9	20.5	-	32.3	-	-	
3Ph (400v 50Hz) compressor load only (at nominal cooling capacity)																
Power (nominal)	kW	-	-	1.42	2.07	-	2.03	2.26	2.61	3.03	3.92	4.46	4.52	5.29	5.82	
Starting current LRA	A	-	-	18	22	-	26	32	40	48	51	62	68	71	71	
Nominal current FLA	A	-	-	3.6	4.8	-	4.2	4.2	4.9	7.1	7.2	7.7	8.7	9.5	11.9	
Sound Pressure Levels (SPL) at 10m distance in free field conditions @ 27°C external ambient.																
Fan speed max	dBA	34	34	34	34	33	33	33	34	37	38	37	37	37	39	
	NR	28	28	28	28	27	27	27	27	30	31	30	30	30	32	
Condenser fan (1Ph 230V 50Hz)																
Airflow (max speed)	m³/s	0.40	0.40	0.97	0.97	0.97	0.97	0.97	0.97	0.97	0.97	1.85	1.85	1.85	1.85	
Fan motor rating	kW	0.65	0.65	0.13	0.13	0.13	0.13	0.13	0.13	0.13	0.13	2x0.13	2x0.13	2x0.13	2x0.13	
Nominal current FLA	A	0.4	0.4	0.6	0.6	0.6	0.6	0.6	0.6	0.6	0.6	2x0.6	2x0.6	2x0.6	2x0.6	
Fans: No. x diameter	#x mm	1x350	1x350	1x457	1x457	1x457	1x457	1x457	1x457	1x457	1x457	2x457	2x457	2x457	2x457	
Fans max speed	r.p.m	940	940	940	940	940	940	940	940	940	940	940	940	940	940	

PERFORMANCE DATA

MRC+ 15 – 180 CAPACITIES – 1 & 3 Phase
 (Return gas temperature 20°C, 0°K sub cooling)

R407A

MODEL	Ambient Temp °C	HP	EVAPORATING TEMPERATURE °C													
			-15		-10		-5		0		5		7		10	
			COOLING CAPACITY AND POWER INPUT kW													
		CAP.	POWER	CAP.	POWER	CAP.	POWER	CAP.	POWER	CAP.	POWER	CAP.	POWER	CAP.	POWER	
MRC+ 15	27	1/2	0.90	0.52	1.20	0.58	1.55	0.65	1.90	0.71	2.37	0.77	2.39	0.80	2.45	0.82
	30		0.84	0.52	1.14	0.58	1.47	0.65	1.81	0.72	2.25	0.79	2.28	0.81	2.32	0.85
	32		0.81	0.52	1.09	0.58	1.42	0.66	1.74	0.77	2.19	0.80	2.19	0.83	2.24	0.86
	35		0.74	0.53	1.03	0.58	1.34	0.67	1.65	0.75	2.05	0.83	2.07	0.85	2.10	0.89
MRC+ 20	27	5/8	1.17	0.68	1.56	0.76	2.01	0.85	2.47	0.94	3.07	1.02	3.11	1.05	3.18	1.09
	30		1.10	0.68	1.47	0.77	1.91	0.86	2.35	0.95	2.92	1.04	2.96	1.07	3.01	1.12
	32		1.05	0.68	1.42	0.77	1.84	0.86	2.26	1.01	2.84	1.06	2.85	1.09	2.91	1.14
	35		0.96	0.68	1.34	0.78	1.73	0.88	2.14	0.99	2.66	1.09	2.68	1.13	2.72	1.18
MRC+ 30	27	1 3/8	1.74	0.94	2.23	1.04	2.78	1.15	3.32	1.26	4.03	1.36	4.07	1.43	4.40	1.50
	30		1.64	0.94	2.11	1.05	2.64	1.16	3.16	1.28	3.83	1.39	3.87	1.46	4.16	1.55
	32		1.57	0.95	2.03	1.06	2.53	1.17	3.03	1.35	3.74	1.41	3.72	1.49	4.02	1.58
	35		1.44	0.95	1.91	1.07	2.39	1.20	2.87	1.33	3.50	1.45	3.50	1.54	3.75	1.64
MRC+ 40	27	1 1/2	2.52	1.40	3.18	1.50	3.93	1.64	4.67	1.80	5.46	1.99	5.75	2.08	6.25	2.21
	30		2.39	1.42	3.03	1.53	3.74	1.68	4.64	1.85	5.18	2.05	5.46	2.14	5.90	2.29
	32		2.31	1.43	2.92	1.56	3.60	1.70	4.28	1.97	5.04	2.10	5.25	2.19	5.68	2.34
	35		2.12	1.44	2.76	1.58	3.41	1.75	4.04	1.94	4.69	2.16	4.91	2.26	5.28	2.42
MRC+ 45	27	1 1/2	2.48	1.02	3.01	1.05	3.62	1.10	4.22	1.18	4.87	1.29	5.11	1.37	5.52	1.47
	30		2.39	1.09	2.90	1.13	3.49	1.18	4.08	1.25	4.69	1.37	4.92	1.45	5.29	1.57
	32		2.33	1.14	2.89	1.17	3.39	1.22	3.95	1.36	4.61	1.42	4.78	1.52	5.31	1.64
	35		2.19	1.22	2.72	1.26	3.25	1.31	3.79	1.39	4.36	1.53	4.55	1.62	4.89	1.75
MRC+ 50	27	2	3.31	1.50	4.05	1.54	4.89	1.59	5.73	1.67	6.64	1.78	6.98	1.83	7.57	1.88
	30		3.20	1.60	3.90	1.65	4.72	1.70	5.54	1.78	6.39	1.89	6.73	1.93	7.26	2.02
	32		3.12	1.67	3.89	1.72	4.58	1.76	5.37	1.93	6.29	1.96	6.54	2.02	7.29	2.10
	35		2.92	1.79	3.66	1.84	4.39	1.89	5.15	1.98	5.94	2.10	6.23	2.14	6.71	2.24
MRC+ 60	27	2 1/2	3.89	1.66	4.75	1.71	5.74	1.77	6.72	1.86	7.80	1.98	8.19	2.03	8.89	2.09
	30		3.75	1.78	4.58	1.83	5.55	1.89	6.51	1.98	7.50	2.10	7.90	2.15	8.52	2.25
	32		3.66	1.86	4.56	1.91	5.38	1.96	6.30	2.15	7.38	2.18	7.68	2.25	8.56	2.34
	35		3.43	1.99	4.29	2.05	5.16	2.11	6.05	2.21	6.97	2.34	7.31	2.40	7.88	2.50
MRC+ 80	27	3	4.63	1.90	5.65	1.96	6.84	2.02	8.00	2.13	9.28	2.27	9.75	2.33	10.58	2.41
	30		4.47	2.04	5.45	2.10	6.60	2.17	7.75	2.28	8.93	2.42	9.41	2.48	10.14	2.59
	32		4.35	2.14	5.43	2.20	6.40	2.26	7.50	2.48	8.78	2.52	9.14	2.60	10.18	2.70
	35		4.08	2.30	5.11	2.37	6.14	2.44	7.20	2.55	8.30	2.71	8.70	2.77	9.37	2.90
MRC+ 90	27	3 1/2	5.40	2.19	6.60	2.26	7.98	2.34	9.35	2.46	10.84	2.63	11.39	2.70	12.35	2.79
	30		5.21	2.37	6.37	2.43	7.71	2.51	9.04	2.64	10.43	2.80	10.98	2.88	11.84	3.00
	32		5.08	2.48	6.34	2.55	7.47	2.62	8.76	2.88	10.25	2.93	10.67	3.02	11.89	3.14
	35		4.77	2.67	5.96	2.75	7.17	2.83	8.40	2.96	9.69	3.15	10.16	3.23	10.94	3.37
MRC+ 100	27	4	6.19	2.89	7.71	2.97	9.14	3.08	10.71	3.24	12.41	3.45	13.05	3.54	14.15	3.65
	30		5.97	3.09	7.29	3.17	8.83	3.27	10.36	3.43	11.95	3.64	12.58	3.73	13.57	3.89
	32		5.82	3.21	7.02	3.25	8.56	3.39	10.03	3.72	11.75	3.78	12.22	3.88	13.62	4.04
	35		5.46	3.43	6.83	3.53	8.21	3.63	9.63	3.80	11.10	4.03	11.63	4.12	12.54	4.30
MRC+ 130	27	4 1/2	7.09	3.30	8.84	3.39	10.47	3.51	12.27	3.69	14.22	3.92	14.95	4.03	16.21	4.15
	30		6.84	3.53	8.36	3.62	10.11	3.74	11.87	3.91	13.69	4.15	14.42	4.25	15.54	4.43
	32		6.67	3.67	8.05	3.71	9.81	3.87	11.50	4.24	13.46	4.31	14.00	4.43	15.61	4.60
	35		6.25	3.92	7.83	4.04	9.41	4.15	11.03	4.33	12.72	4.60	13.33	4.70	14.36	4.91

MODEL	Ambient Temp °C	HP	EVAPORATING TEMPERATURE °C													
			-15		-10		-5		0		5		7		10	
			COOLING CAPACITY AND POWER INPUT kW													
			CAP.	POWER	CAP.	POWER	CAP.	POWER	CAP.	POWER	CAP.	POWER	CAP.	POWER	CAP.	POWER
MRC+ 150	27	5	7.74	3.34	9.64	3.44	11.43	3.56	13.38	3.74	15.51	3.97	16.30	4.08	17.68	4.20
	30		7.46	3.57	9.11	3.67	11.03	3.78	12.95	3.96	14.93	4.20	15.72	4.30	16.95	4.49
	32		7.28	3.71	8.78	3.76	10.70	3.92	12.54	4.29	14.68	4.36	15.28	4.48	17.02	4.66
	35		6.82	3.97	8.54	4.09	10.26	4.20	12.03	4.39	13.87	4.66	14.54	4.76	15.67	4.97
MRC+ 165	27	6	9.23	3.89	11.50	4.00	13.63	4.14	15.96	4.35	18.51	4.63	19.45	4.76	21.09	4.90
	30		8.90	4.16	10.87	4.28	13.16	4.41	15.44	4.62	17.81	4.91	18.76	5.03	20.22	5.25
	32		8.68	4.33	10.47	4.38	12.76	4.58	14.96	5.02	17.51	5.10	18.22	5.24	20.31	5.45
	35		8.14	4.64	10.19	4.78	12.24	4.91	14.35	5.13	16.55	5.45	17.34	5.57	18.69	5.82
MRC+ 180	27	7 1/2	10.20	4.27	12.71	4.39	15.06	4.55	17.64	4.78	20.45	5.09	21.50	5.23	23.31	5.39
	30		9.84	4.57	12.02	4.70	14.55	4.85	17.07	5.08	19.68	5.39	20.73	5.53	22.35	5.77
	32		9.60	4.76	11.57	4.82	14.10	5.04	16.53	5.52	19.35	5.61	20.14	5.77	22.44	6.00
	35		8.99	5.11	11.26	5.26	13.53	5.40	15.86	5.65	18.29	6.00	19.17	6.14	20.66	6.41

PERFORMANCE DATA

MRC+ 15 – 180 CAPACITIES – 1 & 3 Phase
 (Return gas temperature 20°C, 0°K sub cooling)

R407F

MODEL	Ambient Temp °C	HP	EVAPORATING TEMPERATURE °C													
			-15		-10		-5		0		5		7		10	
			COOLING CAPACITY AND POWER INPUT kW													
			CAP.	POWER	CAP.	POWER	CAP.	POWER	CAP.	POWER	CAP.	POWER	CAP.	POWER	CAP.	POWER
MRC+ 15	27	1/2	0.88	0.58	1.19	0.64	1.54	0.71	1.93	0.76	2.37	0.84	2.42	0.86	2.49	0.81
	30		0.83	0.59	1.12	0.64	1.46	0.72	1.81	0.79	2.26	0.86	2.30	0.88	2.37	0.92
	32		0.79	0.59	1.07	0.64	1.40	0.72	1.74	0.80	2.21	0.87	2.22	0.90	2.29	0.94
	35		0.74	0.58	1.01	0.64	1.32	0.74	1.64	0.82	2.05	0.90	2.08	0.92	2.14	0.97
MRC+ 20	27	5/8	1.15	0.76	1.54	0.84	2.00	0.93	2.50	1.01	3.08	1.11	3.14	1.14	3.23	1.18
	30		1.07	0.76	1.45	0.85	1.89	0.94	2.34	1.04	2.93	1.13	2.99	1.16	3.07	1.21
	32		1.03	0.77	1.39	0.86	1.81	0.95	2.26	1.06	2.87	1.15	2.88	1.19	2.97	1.24
	35		0.96	0.76	1.31	0.86	1.71	0.97	2.13	1.08	2.66	1.19	2.70	1.23	2.77	1.29
MRC+ 30	27	1 3/8	1.72	1.05	2.20	1.15	2.75	1.26	3.36	1.34	4.05	1.47	4.11	1.54	4.47	1.62
	30		1.61	1.06	2.08	1.16	2.61	1.28	3.15	1.40	3.84	1.51	3.91	1.58	4.24	1.67
	32		1.54	1.06	1.99	1.17	2.50	1.29	3.03	1.42	3.76	1.53	3.76	1.62	4.09	1.71
	35		1.44	1.06	1.87	1.18	2.36	1.31	2.85	1.45	3.50	1.57	3.53	1.67	3.82	1.79
MRC+ 40	27	1 1/2	2.49	1.58	3.14	1.68	3.89	1.80	4.72	1.92	5.48	2.16	5.81	2.25	6.34	2.39
	30		2.34	1.60	2.98	1.71	3.71	1.85	4.62	2.03	5.20	2.24	5.52	2.33	6.01	2.49
	32		2.25	1.61	2.87	1.73	3.56	1.88	4.28	2.06	5.08	2.29	5.30	2.39	5.79	2.55
	35		2.12	1.61	2.70	1.75	3.35	1.92	4.02	2.12	4.69	2.36	4.96	2.46	5.38	2.64
MRC+ 45	27	1 1/2	2.44	1.15	2.97	1.17	3.58	1.21	4.27	1.25	4.89	1.39	5.16	1.48	5.60	1.58
	30		2.35	1.23	2.86	1.25	3.46	1.29	4.06	1.37	4.71	1.49	4.97	1.57	5.39	1.70
	32		2.28	1.28	2.84	1.30	3.35	1.35	3.95	1.42	4.65	1.55	4.83	1.65	5.42	1.78
	35		2.19	1.37	2.66	1.39	3.20	1.44	3.77	1.52	4.36	1.66	4.59	1.76	4.97	1.91
MRC+ 50	27	2	3.26	1.69	4.00	1.72	4.85	1.76	5.80	1.79	6.67	1.93	7.05	1.98	7.69	2.04
	30		3.13	1.81	3.84	1.84	4.68	1.87	5.52	1.95	6.42	2.06	6.80	2.10	7.40	2.19
	32		3.04	1.89	3.82	1.91	4.53	1.95	5.37	2.02	6.33	2.13	6.61	2.19	7.43	2.28
	35		2.92	2.01	3.58	2.03	4.32	2.08	5.13	2.16	5.94	2.29	6.28	2.33	6.83	2.45
MRC+ 60	27	2 1/2	3.83	1.88	4.70	1.90	5.69	1.95	6.81	1.99	7.82	2.14	8.27	2.20	9.02	2.26
	30		3.68	2.02	4.51	2.04	5.49	2.08	6.48	2.17	7.53	2.29	7.98	2.34	8.68	2.44
	32		3.57	2.10	4.48	2.13	5.31	2.17	6.30	2.25	7.43	2.38	7.76	2.44	8.72	2.55
	35		3.43	2.24	4.20	2.27	5.08	2.32	6.02	2.41	6.98	2.55	7.37	2.61	8.01	2.73
MRC+ 80	27	3	4.56	2.15	5.59	2.19	6.77	2.24	8.10	2.28	9.31	2.47	9.85	2.53	10.74	2.61
	30		4.38	2.32	5.37	2.35	6.54	2.40	7.71	2.50	8.96	2.64	9.50	2.70	10.33	2.81
	32		4.25	2.42	5.33	2.45	6.32	2.50	7.50	2.60	8.85	2.75	9.23	2.82	10.38	2.94
	35		4.08	2.59	5.00	2.62	6.04	2.69	7.16	2.79	8.30	2.96	8.77	3.02	9.54	3.17
MRC+ 90	27	3 1/2	5.32	2.49	6.53	2.53	7.91	2.58	9.46	2.64	10.87	2.86	11.50	2.93	12.54	3.02
	30		5.11	2.69	6.27	2.72	7.63	2.78	9.01	2.90	10.47	3.06	11.10	3.13	12.06	3.27
	32		4.96	2.81	6.23	2.85	7.38	2.91	8.76	3.02	10.33	3.20	10.78	3.28	12.12	3.43
	35		4.76	3.01	5.84	3.05	7.05	3.13	8.36	3.25	9.69	3.44	10.24	3.52	11.13	3.69
MRC+ 100	27	4	6.10	3.29	7.63	3.33	9.06	3.41	10.83	3.47	12.46	3.75	13.17	3.84	14.36	3.95
	30		5.85	3.52	7.18	3.56	8.74	3.63	10.32	3.77	11.99	3.98	12.71	4.06	13.82	4.23
	32		5.69	3.64	6.90	3.63	8.46	3.76	10.03	3.91	11.83	4.12	12.35	4.23	13.89	4.41
	35		5.46	3.87	6.69	3.92	8.08	4.01	9.58	4.16	11.11	4.40	11.73	4.50	12.75	4.71
MRC+ 130	27	4 1/2	6.99	3.73	8.74	3.78	10.38	3.87	12.41	3.95	14.27	4.26	15.09	4.36	16.45	4.49
	30		6.70	4.00	8.23	4.04	10.02	4.13	11.82	4.29	13.74	4.53	14.56	4.62	15.83	4.81
	32		6.51	4.15	7.90	4.13	9.69	4.28	11.50	4.45	13.56	4.69	14.15	4.81	15.91	5.01
	35		6.25	4.40	7.66	4.46	9.26	4.57	10.98	4.74	12.72	5.01	13.44	5.12	14.61	5.36

MODEL	Ambient Temp °C	HP	EVAPORATING TEMPERATURE °C													
			-15		-10		-5		0		5		7		10	
			COOLING CAPACITY AND POWER INPUT kW													
			CAP.	POWER	CAP.	POWER	CAP.	POWER	CAP.	POWER	CAP.	POWER	CAP.	POWER	CAP.	POWER
MRC+ 150	27	5	7.62	3.78	9.53	3.83	11.32	3.92	13.54	4.00	15.57	4.31	16.46	4.41	17.95	4.55
	30		7.31	4.05	8.98	4.09	10.93	4.18	12.89	4.34	14.98	4.58	15.88	4.68	17.27	4.87
	32		7.10	4.20	8.62	4.18	10.57	4.34	12.54	4.50	14.79	4.75	15.43	4.88	17.35	5.08
	35		6.82	4.46	8.35	4.52	10.10	4.63	11.97	4.80	13.88	5.08	14.66	5.19	15.94	5.43
MRC+ 165	27	6	9.09	4.41	11.37	4.47	13.50	4.57	16.15	4.66	18.57	5.03	19.64	5.15	21.41	5.31
	30		8.72	4.73	10.71	4.78	13.03	4.88	15.38	5.07	17.87	5.36	18.95	5.47	20.60	5.70
	32		8.48	4.91	10.28	4.89	12.61	5.07	14.96	5.26	17.64	5.56	18.41	5.70	20.70	5.94
	35		8.13	5.22	9.97	5.29	12.05	5.41	14.28	5.62	16.55	5.95	17.49	6.08	19.01	6.37
MRC+ 180	27	7 1/2	10.05	4.84	12.57	4.91	14.92	5.03	17.85	5.12	20.53	5.53	21.71	5.66	23.66	5.84
	30		9.64	5.20	11.83	5.26	14.41	5.37	17.00	5.58	19.75	5.89	20.94	6.01	22.77	6.27
	32		9.37	5.40	11.36	5.37	13.93	5.58	16.53	5.79	19.50	6.12	20.35	6.28	22.88	6.54
	35		8.99	5.74	11.02	5.82	13.31	5.96	15.79	6.19	18.30	6.55	19.33	6.69	21.01	7.01

PERFORMANCE DATA

MRC+ 15 – 180 CAPACITIES – 1 & 3 Phase
 (Return gas temperature 20°C, 0°K sub cooling)

R404A

MODEL	Ambient Temp °C	HP	EVAPORATING TEMPERATURE °C													
			-15		-10		-5		0		5		7		10	
			COOLING CAPACITY AND POWER INPUT kW													
			CAP.	POWER	CAP.	POWER	CAP.	POWER	CAP.	POWER	CAP.	POWER	CAP.	POWER	CAP.	POWER
MRC+ 15	27	1/2	0.95	0.60	1.23	0.67	1.54	0.73	1.86	0.78	2.26	0.84	2.28	0.85	2.32	0.87
	30		0.88	0.60	1.15	0.67	1.45	0.73	1.75	0.80	2.13	0.85	2.15	0.87	2.18	0.89
	32		0.84	0.60	1.10	0.67	1.38	0.74	1.67	0.80	2.04	0.86	2.06	0.88	2.08	0.91
	35		0.79	0.60	1.03	0.67	1.30	0.75	1.57	0.82	1.91	0.88	1.92	0.90	1.94	0.94
MRC+ 20	27	5/8	1.23	0.79	1.59	0.87	2.00	0.95	2.41	1.04	2.93	1.01	2.96	1.13	3.01	1.16
	30		1.15	0.79	1.49	0.88	1.88	0.96	2.27	1.05	2.76	1.13	2.79	1.15	2.82	1.18
	32		1.09	0.79	1.43	0.88	1.80	0.97	2.17	1.06	2.65	1.14	2.67	1.17	2.70	1.20
	35		1.02	0.79	1.33	0.88	1.68	0.98	2.03	1.08	2.48	1.17	2.50	1.18	2.52	1.24
MRC+ 30	27	1 3/8	1.84	1.09	2.28	1.19	2.75	1.29	3.24	1.39	3.85	1.47	3.89	1.53	4.16	1.59
	30		1.72	1.09	2.13	1.20	2.59	1.30	3.04	1.41	3.63	1.50	3.65	1.56	3.90	1.63
	32		1.64	1.09	2.04	1.20	2.48	1.31	2.91	1.42	3.48	1.52	3.49	1.59	3.73	1.66
	35		1.53	1.09	1.91	1.21	2.32	1.33	2.73	1.45	3.25	1.55	3.26	1.63	3.48	1.72
MRC+ 40	27	1 1/2	2.66	1.64	3.24	1.74	3.89	1.85	4.56	1.99	5.22	2.16	5.49	2.23	5.91	2.35
	30		2.51	1.65	3.06	1.76	3.67	1.89	4.47	2.04	4.90	2.22	5.15	2.30	5.53	2.42
	32		2.40	1.66	2.94	1.77	3.52	1.91	4.11	2.07	4.69	2.26	4.92	2.34	5.28	2.47
	35		2.25	1.66	2.75	1.80	3.30	1.95	3.84	2.12	4.36	2.32	4.58	2.41	4.89	2.54
MRC+ 45	27	1 1/2	2.61	1.19	3.07	1.21	3.58	1.24	4.12	1.29	4.66	1.39	4.87	1.47	5.22	1.56
	30		2.51	1.27	2.93	1.28	3.43	1.32	3.93	1.37	4.44	1.48	4.64	1.55	4.96	1.66
	32		2.43	1.32	2.91	1.33	3.31	1.37	3.80	1.43	4.29	1.53	4.48	1.62	4.94	1.73
	35		2.32	1.41	2.71	1.43	3.15	1.46	3.60	1.52	4.06	1.63	4.24	1.72	4.53	1.84
MRC+ 50	27	2	3.49	1.76	4.13	1.78	4.85	1.80	5.59	1.85	6.35	1.93	6.66	1.96	7.16	2.00
	30		3.35	1.87	3.95	1.89	4.63	1.91	5.34	1.96	6.05	2.04	6.35	2.07	6.81	2.13
	32		3.24	1.94	3.91	1.96	4.48	1.98	5.16	2.03	5.85	2.11	6.13	2.15	6.78	2.21
	35		3.09	2.07	3.64	2.09	4.26	2.11	4.90	2.16	5.53	2.25	5.80	2.28	6.21	2.35
MRC+ 60	27	2 1/2	4.10	1.95	4.85	1.97	5.69	2.00	6.56	2.05	7.45	2.14	7.82	2.18	8.41	2.22
	30		3.93	2.08	4.64	2.10	5.44	2.12	6.26	2.18	7.10	2.27	7.45	2.31	7.99	2.37
	32		3.81	2.16	4.59	2.18	5.26	2.21	6.06	2.26	6.86	2.35	7.20	2.40	7.95	2.47
	35		3.63	2.31	4.28	2.33	4.99	2.36	5.75	2.41	6.49	2.51	6.80	2.55	7.29	2.63
MRC+ 80	27	3	4.88	2.24	5.77	2.27	6.77	2.29	7.81	2.36	8.87	2.47	9.31	2.51	10.01	2.56
	30		4.68	2.39	5.52	2.42	6.47	2.45	7.46	2.51	8.45	2.62	8.87	2.66	9.51	2.74
	32		4.53	2.49	5.46	2.52	6.26	2.55	7.21	2.61	8.17	2.72	8.57	2.77	9.47	2.85
	35		4.32	2.67	5.09	2.70	5.95	2.72	6.84	2.79	7.73	2.91	8.10	2.95	8.68	3.04
MRC+ 90	27	3 1/2	5.69	2.59	6.74	2.62	7.91	2.65	9.12	2.73	10.35	2.86	10.87	2.90	11.68	2.96
	30		5.46	2.77	6.44	2.80	7.56	2.84	8.71	2.91	9.87	3.04	10.35	3.09	11.10	3.18
	32		5.29	2.89	6.38	2.92	7.31	2.96	8.42	3.03	9.54	3.16	10.00	3.22	11.05	3.32
	35		5.04	3.11	5.94	3.14	6.94	3.17	7.99	3.25	9.02	3.39	9.45	3.44	10.14	3.54
MRC+ 100	27	4	6.52	3.43	7.88	3.46	9.06	3.50	10.45	3.60	11.86	3.75	12.45	3.81	13.39	3.88
	30		6.25	3.63	7.38	3.67	8.66	3.70	9.97	3.80	11.31	3.95	11.86	4.01	12.72	4.12
	32		6.06	3.75	7.06	3.73	8.37	3.83	9.65	3.92	10.93	4.08	11.46	4.15	12.66	4.26
	35		5.78	3.99	6.81	4.03	7.95	4.07	9.15	4.16	10.33	4.33	10.83	4.39	11.61	4.52
MRC+ 130	27	4 1/2	7.47	3.89	9.03	3.92	10.38	3.97	11.97	4.08	13.59	4.26	14.26	4.32	15.34	4.41
	30		7.17	4.12	8.45	4.16	9.92	4.21	11.42	4.32	12.95	4.49	13.59	4.55	14.57	4.68
	32		6.95	4.27	8.09	4.24	9.59	4.35	11.05	4.46	12.52	4.64	13.13	4.72	14.50	4.85
	35		6.62	4.55	7.80	4.59	9.11	4.63	10.49	4.74	11.84	4.94	12.41	5.00	13.30	5.15

MODEL	Ambient Temp °C	HP	EVAPORATING TEMPERATURE °C													
			-15		-10		-5		0		5		7		10	
			COOLING CAPACITY AND POWER INPUT kW													
			CAP.	POWER	CAP.	POWER	CAP.	POWER	CAP.	POWER	CAP.	POWER	CAP.	POWER	CAP.	POWER
MRC+ 150	27	5	8.15	3.94	9.84	3.97	11.32	4.02	13.06	4.13	14.82	4.31	15.56	4.38	16.73	4.46
	30		7.82	4.17	9.22	4.22	10.82	4.26	12.46	4.37	14.13	4.55	14.82	4.61	15.89	4.75
	32		7.58	4.32	8.83	4.29	10.46	4.41	12.06	4.52	13.65	4.70	14.32	4.78	15.82	4.92
	35		7.22	4.60	8.51	4.65	9.94	4.69	11.44	4.80	12.91	5.00	13.53	5.07	14.51	5.22
MRC+ 165	27	6	9.72	4.59	11.74	4.63	13.50	4.69	15.58	4.82	17.68	5.03	18.56	5.11	19.95	5.21
	30		9.32	4.87	11.00	4.93	12.90	4.98	14.87	5.11	16.86	5.31	17.68	5.39	18.96	5.55
	32		9.04	5.05	10.53	5.02	12.48	5.16	14.38	5.29	16.29	5.49	17.08	5.60	18.87	5.75
	35		8.61	5.39	10.15	5.44	11.85	5.49	13.64	5.62	15.41	5.85	16.15	5.93	17.31	6.11
MRC+ 180	27	7 1/2	10.74	5.04	12.98	5.09	14.92	5.16	17.22	5.30	19.54	5.53	20.52	5.62	22.05	5.73
	30		10.30	5.36	12.16	5.42	14.26	5.47	16.43	5.62	18.63	5.85	19.54	5.93	20.95	6.10
	32		9.99	5.56	11.64	5.52	13.79	5.67	15.90	5.82	18.00	6.05	18.88	6.16	20.86	6.33
	35		9.52	5.93	11.22	5.99	13.10	6.05	15.08	6.19	17.03	6.45	17.84	6.53	19.13	6.73

PERFORMANCE DATA

MRC+ 15 – 180 CAPACITIES – 1 & 3 Phase
(Return gas temperature 20°C, 0°K sub cooling)

R448A – R449A

MODEL	Ambient Temp °C	HP	EVAPORATING TEMPERATURE °C													
			-15		-10		-5		0		5		7		10	
			COOLING CAPACITY AND POWER INPUT kW													
			CAP.	POWER	CAP.	POWER	CAP.	POWER	CAP.	POWER	CAP.	POWER	CAP.	POWER	CAP.	POWER
MRC+ 15	27	1/2	0.83	0.53	1.10	0.61	1.41	0.67	1.74	0.73	2.17	0.80	2.21	0.81	2.28	0.85
	30		0.77	0.54	1.04	0.61	1.35	0.67	1.66	0.75	2.08	0.81	2.12	0.83	2.18	0.86
	32		0.74	0.54	1.00	0.61	1.29	0.68	1.60	0.74	2.01	0.81	2.05	0.84	2.10	0.88
	35		0.71	0.54	0.95	0.61	1.24	0.69	1.54	0.76	1.92	0.83	1.95	0.86	2.00	0.90
MRC+ 20	27	5/8	1.08	0.71	1.42	0.79	1.83	0.87	2.26	0.97	2.81	1.06	2.87	1.08	2.95	1.13
	30		1.01	0.71	1.34	0.80	1.75	0.88	2.16	0.98	2.69	1.07	2.74	1.10	2.81	1.14
	32		0.97	0.71	1.30	0.80	1.68	0.89	2.08	0.99	2.61	1.08	2.66	1.11	2.73	1.16
	35		0.92	0.72	1.23	0.80	1.60	0.90	1.99	1.01	2.49	1.11	2.54	1.14	2.60	1.19
MRC+ 30	27	1 3/8	1.61	0.98	2.04	1.09	2.52	1.19	3.04	1.30	3.69	1.40	3.77	1.47	4.08	1.55
	30		1.51	0.99	1.92	1.10	2.40	1.20	2.89	1.32	3.54	1.43	3.59	1.49	3.89	1.58
	32		1.45	0.99	1.86	1.09	2.32	1.20	2.80	1.33	3.43	1.44	3.48	1.52	3.77	1.61
	35		1.38	1.00	1.76	1.10	2.20	1.23	2.67	1.36	3.27	1.47	3.31	1.56	3.59	1.66
MRC+ 40	27	1 1/2	2.33	1.48	2.90	1.59	3.56	1.70	4.27	1.87	5.00	2.06	5.33	2.14	5.80	2.29
	30		2.21	1.50	2.76	1.61	3.41	1.74	4.25	1.91	4.78	2.11	5.07	2.20	5.52	2.34
	32		2.13	1.51	2.68	1.61	3.29	1.76	3.95	1.94	4.62	2.15	4.90	2.23	5.34	2.39
	35		2.02	1.52	2.54	1.64	3.14	1.80	3.76	1.98	4.38	2.20	4.66	2.30	5.05	2.44
MRC+ 45	27	1 1/2	2.28	1.07	2.74	1.10	3.27	1.14	3.86	1.21	4.47	1.33	4.72	1.41	5.12	1.52
	30		2.21	1.16	2.64	1.17	3.18	1.22	3.73	1.28	4.33	1.41	4.56	1.48	4.95	1.60
	32		2.15	1.20	2.65	1.21	3.10	1.26	3.65	1.34	4.23	1.45	4.47	1.55	4.99	1.67
	35		2.09	1.29	2.50	1.31	2.99	1.35	3.52	1.42	4.08	1.55	4.31	1.64	4.67	1.77
MRC+ 50	27	2	3.05	1.58	3.69	1.62	4.44	1.66	5.24	1.73	6.09	1.84	6.46	1.88	7.02	1.95
	30		2.95	1.70	3.56	1.72	4.30	1.76	5.07	1.84	5.90	1.94	6.25	1.98	6.80	2.06
	32		2.87	1.77	3.56	1.79	4.19	1.82	4.96	1.90	5.76	2.00	6.11	2.05	6.85	2.14
	35		2.78	1.90	3.36	1.91	4.05	1.95	4.79	2.02	5.56	2.14	5.90	2.18	6.41	2.26
MRC+ 60	27	2 1/2	3.59	1.76	4.33	1.80	5.20	1.84	6.15	1.92	7.14	2.04	7.59	2.09	8.25	2.16
	30		3.46	1.89	4.19	1.92	5.05	1.95	5.95	2.04	6.92	2.16	7.33	2.21	7.97	2.29
	32		3.37	1.97	4.18	1.99	4.92	2.03	5.82	2.11	6.76	2.23	7.18	2.29	8.04	2.39
	35		3.27	2.12	3.95	2.13	4.74	2.18	5.62	2.25	6.53	2.38	6.91	2.43	7.52	2.53
MRC+ 80	27	3	4.27	2.02	5.16	2.07	6.19	2.11	7.32	2.21	8.50	2.36	9.03	2.41	9.82	2.49
	30		4.12	2.18	4.98	2.21	6.01	2.26	7.09	2.35	8.24	2.49	8.73	2.55	9.49	2.65
	32		4.01	2.27	4.97	2.30	5.86	2.35	6.93	2.44	8.05	2.58	8.54	2.65	9.57	2.76
	35		3.89	2.45	4.70	2.47	5.65	2.51	6.69	2.61	7.77	2.76	8.24	2.81	8.96	2.93
MRC+ 90	27	3 1/2	5.07	2.36	6.16	2.41	7.42	2.46	8.79	2.55	10.19	2.70	10.79	2.75	11.77	2.83
	30		4.90	2.53	5.95	2.58	7.18	2.65	8.50	2.73	9.86	2.87	10.44	2.93	11.36	3.03
	32		4.79	2.65	5.94	2.69	7.01	2.76	8.30	2.84	9.63	2.99	10.23	3.06	11.43	3.17
	35		4.63	2.86	5.62	2.91	6.76	2.96	8.01	3.06	9.27	3.21	9.82	3.27	10.65	3.37
MRC+ 100	27	4	5.78	3.12	7.14	3.16	8.43	3.23	10.03	3.37	11.66	3.54	12.38	3.62	13.55	3.71
	30		5.60	3.31	6.76	3.37	8.16	3.42	9.68	3.55	11.28	3.72	11.97	3.80	13.06	3.93
	32		5.46	3.43	6.53	3.42	7.96	3.54	9.45	3.66	11.02	3.84	11.68	3.93	13.13	4.06
	35		5.29	3.66	6.38	3.72	7.68	3.77	9.11	3.89	10.60	4.08	11.29	4.15	12.29	4.30
MRC+ 130	27	4 2/5	6.98	3.54	8.63	3.58	10.10	3.65	11.88	3.79	13.82	4.01	14.67	4.10	15.98	4.23
	30		6.74	3.79	8.15	3.82	9.78	3.89	11.47	4.02	13.32	4.24	14.14	4.32	15.39	4.49
	32		6.57	3.94	7.84	3.92	9.54	4.03	11.19	4.17	13.03	4.38	13.82	4.49	15.49	4.65
	35		6.30	4.23	7.64	4.26	9.17	4.32	10.77	4.45	12.54	4.68	13.29	4.76	14.49	4.95

MODEL	Ambient Temp °C	HP	EVAPORATING TEMPERATURE °C													
			-15		-10		-5		0		5		7		10	
			COOLING CAPACITY AND POWER INPUT kW													
			CAP.	POWER	CAP.	POWER	CAP.	POWER	CAP.	POWER	CAP.	POWER	CAP.	POWER	CAP.	POWER
MRC+ 150	27	5	7.61	3.59	9.40	3.62	11.02	3.69	12.96	3.84	15.07	4.05	16.01	4.15	17.42	4.27
	30		7.35	3.83	8.89	3.87	10.67	3.93	12.51	4.07	14.53	4.30	15.42	4.38	16.78	4.55
	32		7.16	3.98	8.56	3.96	10.41	4.09	12.21	4.23	14.20	4.44	15.08	4.55	16.90	4.71
	35		6.87	4.27	8.34	4.32	10.00	4.38	11.75	4.51	13.67	4.74	14.49	4.83	15.81	5.02
MRC+ 165	27	6	9.02	4.13	11.12	4.19	13.09	4.28	15.43	4.46	17.93	4.73	19.02	4.83	20.81	4.99
	30		8.70	4.42	10.54	4.49	12.64	4.57	14.92	4.74	17.32	5.00	18.40	5.08	20.08	5.32
	32		8.49	4.60	10.18	4.58	12.33	4.74	14.54	4.93	16.96	5.18	17.95	5.32	20.23	5.52
	35		8.13	4.94	9.90	5.00	11.90	5.08	14.06	5.25	16.29	5.54	17.34	5.64	18.89	5.88
MRC+ 180	27	7 1/2	9.96	4.63	12.28	4.69	14.38	4.78	16.93	4.94	19.64	5.25	20.91	5.37	22.92	5.55
	30		9.57	4.93	11.57	5.01	13.87	5.08	16.38	5.27	19.02	5.57	20.27	5.67	22.02	5.90
	32		9.33	5.13	11.16	5.10	13.54	5.27	16.00	5.46	18.64	5.74	19.77	5.89	22.16	6.12
	35		8.93	5.48	10.88	5.55	13.05	5.63	15.43	5.81	17.97	6.12	19.13	6.23	21.44	6.50

MOUNTING MRC+

These units are designed to stand on a flat surface. If the unit is to be wall mounted the following kits are available.

KIT	MRC+ 15-80	MRC+ 90-180
Mounting Bracket	55021100	55021101

Whether floor or wall mounted, it is essential that the mounting surface is capable of supporting the unit weight. Leave space around the unit for air circulation and access for installation and maintenance.

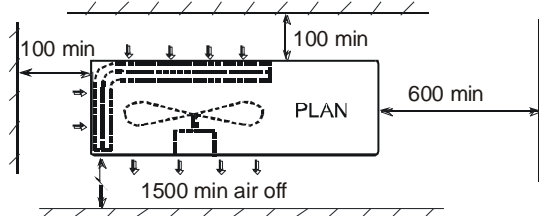

Dimensions in mm.

DIMENSIONS & WEIGHTS MRC+

MRC+ 15-100 (Dimensions in mm.)

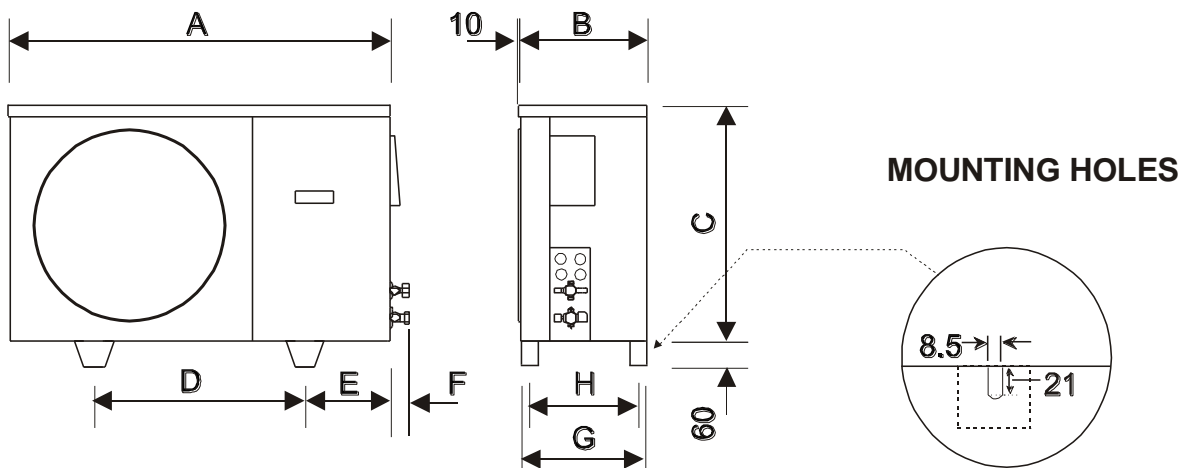

MODEL	A	B	C	D	E	F	G	H	Weight (kg)	
									1 Ph	3 Ph
MRC+ 15	900	300	560	525	185	60	295	275	46	-
MRC+ 20	900	300	560	525	185	60	295	275	47	-
MRC+ 30	900	300	560	525	185	60	295	275	48	48
MRC+ 40	900	300	560	525	185	60	295	275	53	53
MRC+ 45	1000	350	660	495	250	60	345	325	61	-
MRC+ 50	1000	350	660	495	250	60	345	325	64	64
MRC+ 60	1000	350	660	495	250	60	345	325	65	65
MRC+ 80	1000	350	660	495	250	60	345	325	66	66
MRC+ 90	1000	350	760	495	250	70	345	325	76	76
MRC+ 100	1000	350	760	495	250	70	345	325	81	81

MRC+ 130 – 180 (Dimensions in mm.)

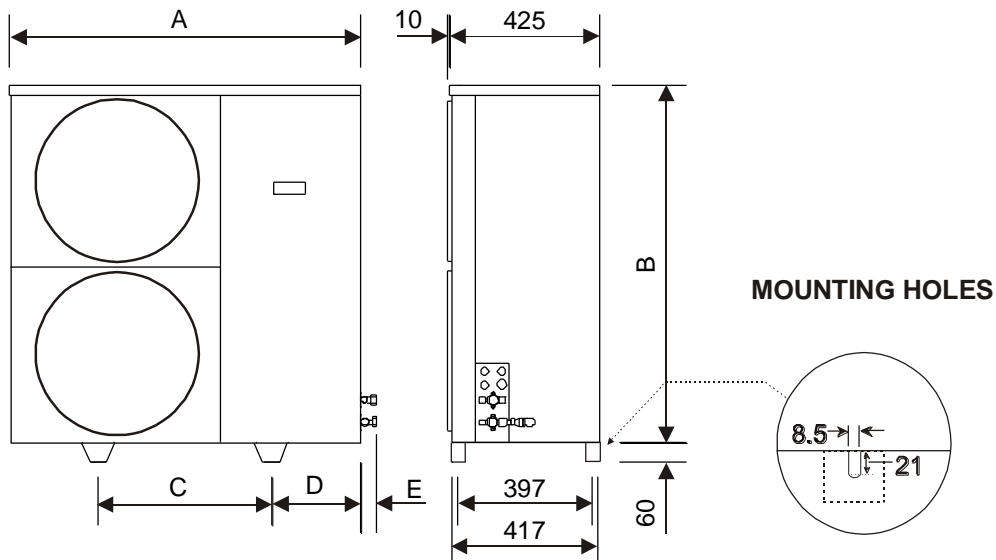

MODEL	A	B	C	D	E	Weight (kg)
MRC+ 130	1000	1020	495	251	100	101
MRC+ 150	1000	1020	495	251	100	103
MRC+ 165	1000	1020	495	251	100	103
MRC+ 180	1100	1215	675	211	95	118

PIPEWORK

Supplied male flare connections (sizes in inches)

Model	MRC+ 15-180														
	15	20	30	40	45	50	60	80	90	100	130	150	165	180	
Liquid	3/8	3/8	3/8	3/8	3/8	3/8	3/8	1/2	1/2	1/2	1/2	1/2	1/2	1/2	1/2
Suction	3/8	1/2	1/2	1/2	1/2	1/2	5/8	5/8	5/8	3/4	3/4	3/4	3/4	7/8*	

* Brazed connections

MAXIMUM PIPE RUNS

45m maximum including 6m lift (20m MRC+ 15-20). There will be no significant loss of capacity for extended pipe runs provided pipes are correctly sized.

CALCULATING EQUIVALENT LENGTHS

The effects of bends and fittings must be taken into account.

Pipe sizes are based on:

Minimum of 2.5 m/s (500 fpm) suction gas velocity for horizontal or downflow.

Minimum of 5.0 m/s (1000 fpm) suction gas velocity for upflow.

Maximum of 20.0 m/s (4000 fpm) suction gas.

Where vertical risers exceed 3m, oil traps must be formed in the pipe. This will help ensure that oil returns to the compressor. Typically fit an oil trap every 3m with a trap at the bottom of the riser.

GOOD PRACTICE

- Keep pipe runs as short as possible.
- Avoid sharp bends
- Fully insulate both suction and liquid including mechanical connections
- Try to avoid running pipes through hot areas.

PIPE SIZES

UNIT SIZE	MAXIMUM LENGTH OF EQUIVALENT SUCTION LINE PIPE SIZES (m)							LIQUID LINE			
	3/8	1/2	5/8	3/4	7/8	1 1/8	1 3/8	3/8	1/2	5/8	3/4
15	7.5	20						20			
20	7.5	20						20			
30		15	45					45			
40		10	36	45				7.5	45		
45		10	36	45				7.5	45		
50		7.5	18	45				7.5	45		
60			14	36	45			7.5	45		
80			11	30	45				45		
90			10	25	45				20	45	
100			7.5	22	45				15	45	
130				15	30	45			12	45	
150				12	27	45			8	45	
165				8	18	45			7.5	40	45
180				7.5	16	45			7.5	35	45

CONNECTING THE UNITS

1. Connecting the pipework:
 - a. Remove the flare nuts from the service valves and release the nitrogen holding charge by slowly opening the valves using a 5mm or 8mm allen key.
 - b. Ensure the suction line is fully insulated.
 - c. Place the flare nuts over the incoming pipework and flare the pipe ends.
 - d. Connect the pipework between the units. Do not leave pipes ends, valves etc open to the atmosphere. Always use 2 spanners when tightening the flare nuts to avoid twisting the pipes. Use a small amount of refrigerant oil on the mating surfaces.
 - e. MRC+ 180 has a 7/8" suction pipe with brazed connections. Use a protective shield to avoid scorching the side panel.

EVACUATING

With the valves open, connect a vacuum pump to the service ports on the outdoor unit valves. Evacuate the interconnecting pipework and indoor unit to 1000 microns (1 Torr) or better. Allow this to be held for a minimum of 15 minutes.

ELECTRICAL

The installer supplies mains, control and interconnecting cables: equipment must be earthed.

Wiring must be carried out in accordance with local and national codes.

Mains supply cables must be size compatible with the recommended fuse.

Cable clamps for use with stranded cables are supplied in units 15 - 100 and should be used to secure incoming/outgoing cables. Installers must supply a method of securing solid sheathed cables.

THREE PHASE UNITS WITH SCROLL COMPRESSORS:

On 3 Ph units sizes 50 - 180 it is possible for the scroll compressor to run backwards.

This becomes obvious on start up - the compressor will not develop a normal running pressure differential and the top will not become warm: it may be excessively noisy. If this happens, switch off the mains power and exchange the two supply phases **not** connected to the indoor unit. This will correct the rotation.

FUSES: The system and its supply/interconnecting wiring must be protected by fuses, preferably High Rupture Current (HRC) motor rated types (to BS EN60269) or miniature circuit breakers to (BS EN60898) or local codes having similar time lag characteristics, that allow starting of the compressor yet still afford close overcurrent protection under running conditions. The ratings below are for HRC motor rated fuses.

1PH FUSE SIZE														
MRC+	15	20	30	40	45	50	60	80	90	100	130	150	165	180
FUSE	16	16	16	20	20	16	20	25	32	32	-	40	-	-

3PH FUSE SIZE													
MRC+	30	40	45	50	60	80	90	100	130	150	165	180	
FUSE	10	10	-	10	10	10	16	16	16	20	20	25	

The ratings are for the outdoor unit only. Currents for the indoor units including heaters if applicable should be noted and the fuse size increased pro-rata.

CONNECTION OF MAINS SUPPLY:

1. Ensure the isolator switch is in the **OFF** position.
2. Remove front panel. (3screws)
3. Isolator body is located on the inside of the right hand panel.
4. To remove the isolator body from the external switch slide the red lever downwards.

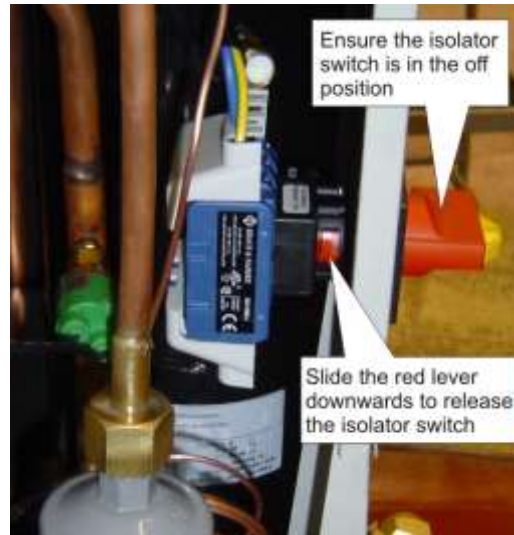

5. Release the main body and lower to the bottom of the unit near the valve panel.
6. Remove lower white plastic cover from the isolator body.
7. Remove knockout hole on the valve panel for your incoming mains supply cable.



8. Route incoming mains cable through the knockout hole and wire to the required terminals and replace lower protective cover.



9. Replace main isolator back into the switch and lock into place by sliding the red lever upwards.



10. Replace covers.

R404A REFRIGERANT

Charging the System:

1. Evacuate the system and interconnecting pipework as page 8 ensuring the service valves are fully open.
2. Allow the evacuated system to draw in the majority of the refrigerant charge.
3. The final charge should be adjusted with the system running.
4. All units are fitted with head pressure control. The link wire across the orange terminals allows the fan to operate at full speed. **THIS SHOULD BE REMOVED AFTER CHARGING**
5. A random start delay of up to 1 minute occurs when mains is first applied. A 3 minute delay occurs between successive compressor operations on all systems.
6. Refrigerant and polyolester oil should be introduced through the Schrader valve the service port on the suction service valve on the outdoor unit. **Ensure the refrigerant is the correct type, as shown on the rating plate.** R404A must always be added in the liquid state.
7. Run the system for a few minutes to allow it to stabilize. Where possible, charge to a sweat line on the evaporator. Typical suction pressures on short lines at UK conditions, with high speed evaporator fan, high speed condenser fan, should be; low temperature system approx 4.4 bar (65 psig).
8. **Systems should not be overcharged, to avoid liquid return to the compressor**
9. **HEAD PRESSURE CONTROL SAGINOMIYA (RGE – ZIN4 – SH)**

The head pressure controller is factory set to suit the refrigerant. It may be necessary to adjust this to suit site conditions, to raise or lower the nominal head pressure.

- a. With the system switched off, connect a high pressure gauge to the liquid line service valve.
- b. Switch on the system, and run for a few minutes to stabilise.

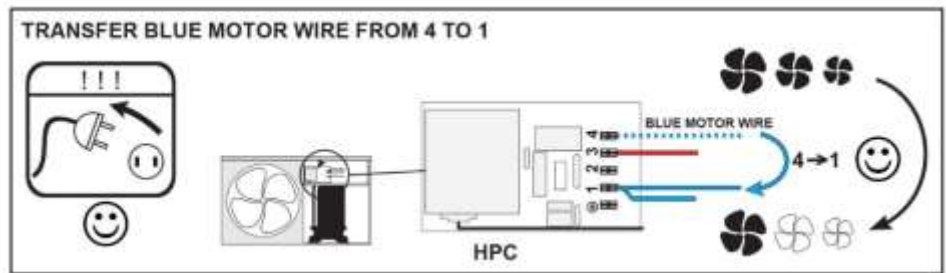

- c. The head pressure should be approximately:

R404A: 210-220 psig (14.5-15.2 barg) to achieve this adjust the screw clockwise to increase pressure or anticlockwise to decrease. Each ½ turn will alter the pressure by approx 5 psig (0.5 barg)

Min fan speed (0 rpm) and fan cut in pressure 200 psig (13.8 barg) are factory set and not adjustable.

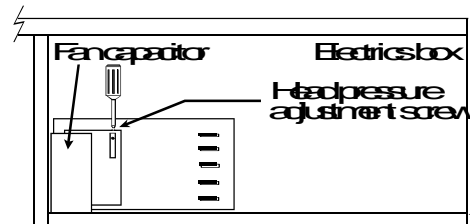

NOTE: The condenser fan may stop if the operating pressure drops below 200 psig (13.8 barg)

10. HEAD PRESSURE CONTROL ALCO (FSY-42S) & SAGINOMIYA (XGE-4C)

The head pressure controller is factory set to suit the refrigerant. It may be necessary to adjust this to suit site conditions, to raise or lower the nominal head pressure.

ALCO (FSY-42S)

- a. With the system switched off, connect a high pressure gauge to the liquid line service valve.
- b. Switch on the system, and run for a few minutes to stabilise.
- c. The head pressure should be approximately:

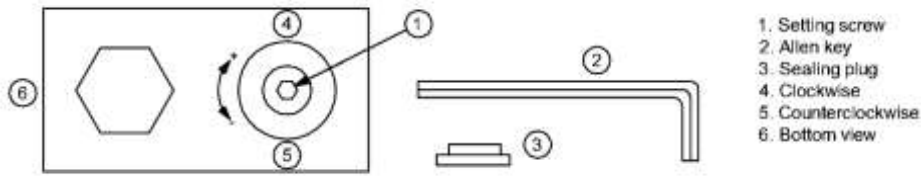

Min fan speed (0 rpm) and fan cut in pressure 200 psig (13.8 barg) are

factory set and not adjustable.

NOTE: The condenser fan may stop if the operating pressure drops below 200 psig (13.8 barg)

R404A: 210-220 psig (14.5-15.2barg) to achieve this remove sealing plug and insert 2mm or 5/64" allen key into setting screw. Turn allen key clockwise (+) or counter clockwise (-) to readjust the setting.

Do not turn setting screw **more than 3 turns clockwise (+3)**. Use following table as a quick guideline for setting:

Pressure changes per turn of adjusting screw:

Pressure change: 9.2 ... 21.2 bar:
 Clockwise ~ +2,5 bar, counter clockwise ~ -2,5 bar

After adjustment, re-insert sealing plug and make sure that it is properly fitted. IP65 protection requires firmly sealed plug

NOTES:

Tolerances for condensing temperatures setpoint: $\pm 2K$

SAGINOMIYA (XGE-4C)

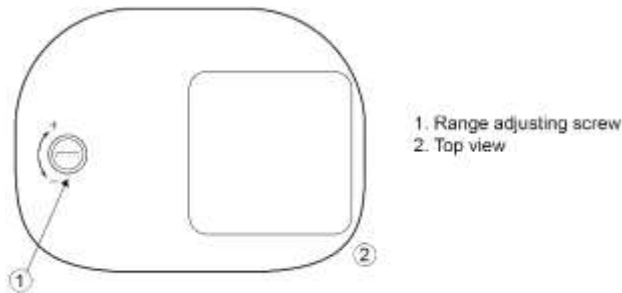

R404A: 210-220 psig (14.5-15.2barg) to achieve this turn the range adjusting screw clockwise (+) for increasing the setting value or counter clockwise (-) for decreasing the setting value.

Pressure changes per 1 turn of adjusting screw:

Pressure change: 10 ... 25bar:
 Clockwise ~ +1.5 bar, counter clockwise ~ -1.5 bar

ROTA-LOCKED VALVES FITTED TO RECIEVER

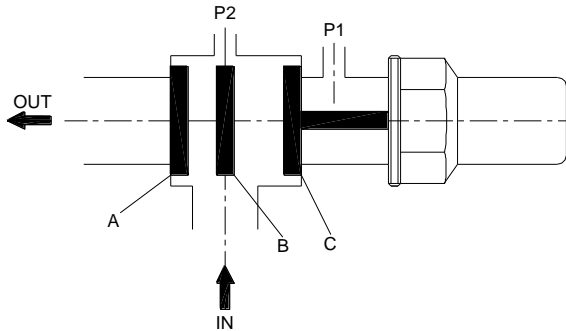

POSITION SPINDLE	FUNCTION
A	OUT CLOSED
B	ALL OPEN
C	P1 CLOSED

Pay attention

- P1, P2: optional gages ports.
- The positions IN - OUT could be inverted according to the employment of client.
- The spindle must be positioned in the position B when the valve will be connected to the unit.

END OF LIFE REQUIRMENTS

Refrigerant must be recovered by a certificated technician before the plant is dismantled. Modern refrigerant recovery machines should be able to remove well over 95% of the refrigerant in an old system.

All recovered HFC refrigerants can either be:

- a) Sent for destruction by incineration at a licenced waste facility
- b) Sent to a specialist plant that can re-process the old refrigerant into a gas with properties identical to virgin refrigerant, to create "reclaimed refrigerant"
- c) Given a basic cleaning process, to create "recycled refrigerant"

Given the HFC supply shortage that will be created by the phase down process, it is worth trying to send the old refrigerant for reclamation as it may have a good residual value. If the old refrigerant is too contaminated it cannot be reclaimed and must be sent for destruction. It is important not to mix different gases in the same recovery cylinder – as this would render them unsuitable for reclamation.

Reclaimed refrigerant can be used in any refrigeration equipment. Recycled refrigerant must always be used with care as it may be contaminated or of unknown composition. The use of recycled refrigerant with a GWP above 2,500 is restricted to either (a) the organisation owning the plant from which the gas was recovered or (b) the organisation that carried out the recovery.

ECO DESIGN INFORMATION TABLES

Model(s): MRC(+)-15 S/P			
Refrigerant fluid(s): R404A			
Item	Symbol	Value	Unit
Evaporating temperature	<i>t</i>	-10°C	°C
Parameters at full load and ambient temperature 32°C			
Rated cooling capacity	<i>P_A</i>	1.10	kW
Rated power input	<i>D_A</i>	0.67	kW
Rated COP	<i>COP_A</i>	1.54	
Parameters at full load and ambient temperature 25°C			
Cooling capacity	<i>P₂</i>	1.27	kW
Power input	<i>D₂</i>	0.66	kW
Rated COP	<i>COP₂</i>	1.92	
Other items			
Capacity control	Fixed		
Contact details	TEV LIMITED Unit 4 Armytage Road Brighouse HD6 1QF		

Model(s): MRC(+)-20 S/P			
Refrigerant fluid(s): R404A			
Item	Symbol	Value	Unit
Evaporating temperature	<i>t</i>	-10°C	°C
Parameters at full load and ambient temperature 32°C			
Rated cooling capacity	<i>P_A</i>	1.43	kW
Rated power input	<i>D_A</i>	0.88	kW
Rated COP	<i>COP_A</i>	1.63	
Parameters at full load and ambient temperature 25°C			
Cooling capacity	<i>P₂</i>	1.64	kW
Power input	<i>D₂</i>	0.86	kW
Rated COP	<i>COP₂</i>	1.91	
Other items			
Capacity control	Fixed		
Contact details	TEV LIMITED Unit 4 Armytage Road Brighouse HD6 1QF		

Model(s): MRC(+)-30 S/P			
Refrigerant fluid(s): R404A			
Item	Symbol	Value	Unit
Evaporating temperature	<i>t</i>	-10°C	°C
Parameters at full load and ambient temperature 32°C			
Rated cooling capacity	<i>P_A</i>	2.04	kW
Rated power input	<i>D_A</i>	1.20	kW
Rated COP	<i>COP_A</i>	1.70	
Parameters at full load and ambient temperature 25°C			
Cooling capacity	<i>P₂</i>	2.35	kW
Power input	<i>D₂</i>	1.18	kW
Rated COP	<i>COP₂</i>	2.00	
Other items			
Capacity control	Fixed		
Contact details	TEV LIMITED Unit 4 Armytage Road Brighouse HD6 1QF		

Model(s): MRC(+)-40 S/P			
Refrigerant fluid(s): R404A			
Item	Symbol	Value	Unit
Evaporating temperature	<i>t</i>	-10°C	°C
Parameters at full load and ambient temperature 32°C			
Rated cooling capacity	<i>P_A</i>	2.94	kW
Rated power input	<i>D_A</i>	1.77	kW
Rated COP	<i>COP_A</i>	1.66	
Parameters at full load and ambient temperature 25°C			
Cooling capacity	<i>P₂</i>	3.30	kW
Power input	<i>D₂</i>	1.71	kW
Rated COP	<i>COP₂</i>	1.96	
Other items			
Capacity control	Fixed		
Contact details	TEV LIMITED Unit 4 Armytage Road Brighouse HD6 1QF		

Model(s): MRC(+)-45 S/P			
Refrigerant fluid(s): R404A			
Item	Symbol	Value	Unit
Evaporating temperature	<i>t</i>	-10°C	°C
Parameters at full load and ambient temperature 32°C			
Rated cooling capacity	<i>P_A</i>	2.91	kW
Rated power input	<i>D_A</i>	1.33	kW
Rated COP	<i>COP_A</i>	2.19	
Parameters at full load and ambient temperature 25°C			
Cooling capacity	<i>P₂</i>	3.11	kW
Power input	<i>D₂</i>	1.24	kW
Rated COP	<i>COP₂</i>	2.51	
Parameters at full load and ambient temperature 43°C (where applicable)			
Cooling capacity	<i>P₃</i>	2.22	kW
Power input	<i>D₃</i>	1.68	kW
Rated COP	<i>COP₃</i>	1.32	
Other items			
Capacity control	Fixed		
Contact details	TEV LIMITED Unit 4 Armytage Road Brighouse HD6 1QF		

Model(s): MRC(+)-50 S/P			
Refrigerant fluid(s): R404A			
Item	Symbol	Value	Unit
Evaporating temperature	<i>t</i>	-10°C	°C
Parameters at full load and ambient temperature 32°C			
Rated cooling capacity	<i>P_A</i>	3.91	kW
Rated power input	<i>D_A</i>	1.96	kW
Rated COP	<i>COP_A</i>	1.99	
Parameters at full load and ambient temperature 25°C			
Cooling capacity	<i>P₂</i>	4.17	kW
Power input	<i>D₂</i>	1.73	kW
Rated COP	<i>COP₂</i>	2.42	
Parameters at full load and ambient temperature 43°C (where applicable)			
Cooling capacity	<i>P₃</i>	2.90	kW
Power input	<i>D₃</i>	2.47	kW
Rated COP	<i>COP₃</i>	1.21	
Other items			
Capacity control	Fixed		
Contact details	TEV LIMITED Unit 4 Armytage Road Brighouse HD6 1QF		

Model(s): MRC(+) 60 3/P			
Refrigerant fluid(s): R404A			
Item	Symbol	Value	Unit
Evaporating temperature	t	-10°C	°C
Parameters at full load and ambient temperature 32°C			
Rated cooling capacity	P_A	4.59	kW
Rated power input	D_A	2.18	kW
Rated COP	$COPA$	2.11	
Parameters at full load and ambient temperature 25°C			
Cooling capacity	P_2	4.90	kW
Power input	D_2	1.91	kW
Rated COP	COP_2	2.57	
Parameters at full load and ambient temperature 43°C (where applicable)			
Cooling capacity	P_3	3.50	kW
Power input	D_3	2.75	kW
Rated COP	COP_3	1.27	
Other items			
Capacity control	Fixed		
Contact details	TEV LIMITED Unit 4 Armytage Road Brighouse HD6 1QF		

Model(s): MRC(+) 30 3/P			
Refrigerant fluid(s): R404A			
Item	Symbol	Value	Unit
Evaporating temperature	t	-10°C	°C
Parameters at full load and ambient temperature 32°C			
Rated cooling capacity	P_A	2.04	kW
Rated power input	D_A	1.20	kW
Rated COP	$COPA$	1.70	
Parameters at full load and ambient temperature 25°C			
Cooling capacity	P_2	2.35	kW
Power input	D_2	1.18	kW
Rated COP	COP_2	2.00	
Other items			
Capacity control	Fixed		
Contact details	TEV LIMITED Unit 4 Armytage Road Brighouse HD6 1QF		

Model(s): MRC(+) 40 3/P			
Refrigerant fluid(s): R404A			
Item	Symbol	Value	Unit
Evaporating temperature	t	-10°C	°C
Parameters at full load and ambient temperature 32°C			
Rated cooling capacity	P_A	2.94	kW
Rated power input	D_A	1.77	kW
Rated COP	$COPA$	1.66	
Parameters at full load and ambient temperature 25°C			
Cooling capacity	P_2	3.35	kW
Power input	D_2	1.71	kW
Rated COP	COP_2	1.96	
Other items			
Capacity control	Fixed		
Contact details	TEV LIMITED Unit 4 Armytage Road Brighouse HD6 1QF		

Model(s): MRC(+) 45 3/P			
Refrigerant fluid(s): R404A			
Item	Symbol	Value	Unit
Evaporating temperature	t	-10°C	°C
Parameters at full load and ambient temperature 32°C			
Rated cooling capacity	P_A	2.91	kW
Rated power input	D_A	1.33	kW
Rated COP	$COPA$	2.19	
Parameters at full load and ambient temperature 25°C			
Cooling capacity	P_2	3.11	kW
Power input	D_2	1.24	kW
Rated COP	COP_2	2.51	
Parameters at full load and ambient temperature 43°C (where applicable)			
Cooling capacity	P_3	2.22	kW
Power input	D_3	1.68	kW
Rated COP	COP_3	1.32	
Other items			
Capacity control	Fixed		
Contact details	TEV LIMITED Unit 4 Armytage Road Brighouse HD6 1QF		

Model(s): MRC(+) 50 3/P			
Refrigerant fluid(s): R404A			
Item	Symbol	Value	Unit
Evaporating temperature	t	-10°C	°C
Parameters at full load and ambient temperature 32°C			
Rated cooling capacity	P_A	3.91	kW
Rated power input	D_A	1.96	kW
Rated COP	COP_A	1.99	
Parameters at full load and ambient temperature 25°C			
Cooling capacity	P_2	4.17	kW
Power input	D_2	1.73	kW
Rated COP	COP_2	2.42	
Parameters at full load and ambient temperature 43°C (where applicable)			
Cooling capacity	P_3	2.98	kW
Power input	D_3	2.47	kW
Rated COP	COP_3	1.21	
Other items			
Capacity control	Fixed		
Contact details	TEV LIMITED Unit 4 Armytage Road Brighouse HD6 1QF		

Model(s): MRC(+) 60 3/P			
Refrigerant fluid(s): R404A			
Item	Symbol	Value	Unit
Evaporating temperature	t	-10°C	°C
Parameters at full load and ambient temperature 32°C			
Rated cooling capacity	P_A	4.59	kW
Rated power input	D_A	2.18	kW
Rated COP	COP_A	2.11	
Parameters at full load and ambient temperature 25°C			
Cooling capacity	P_2	4.90	kW
Power input	D_2	1.91	kW
Rated COP	COP_2	2.57	
Parameters at full load and ambient temperature 43°C (where applicable)			
Cooling capacity	P_3	3.50	kW
Power input	D_3	2.75	kW
Rated COP	COP_3	1.27	
Other items			
Capacity control	Fixed		
Contact details	TEV LIMITED Unit 4 Armytage Road Brighouse HD6 1QF		

Model(s): MRC (+) 80 S/P			
Refrigerant fluid(s): R404A			
Item	Symbol	Value	Unit
Evaporating temperature	t	-10°C	°C
Annual electricity consumption	Q	9517	kWh/a
Seasonal energy performance ratio	$SEPR$	3.53	
Parameters at full load and ambient temperature 32°C (Point A)			
Rated cooling capacity	P_A	5.460	kW
Rated power input	D_A	2.520	kW
Rated COP	COP_A	2.17	
Parameters at part load and ambient temperature 25°C (Point B)			
Declared cooling capacity	P_B	5.83	kW
Declared power input	D_B	2.21	kW
Rated COP	COP_B	2.64	
Parameters at part load and ambient temperature 15°C (Point C)			
Declared cooling capacity	P_C	6.79	kW
Declared power input	D_C	1.73	kW
Rated COP	COP_C	3.93	
Parameters at part load and ambient temperature 5°C (Point D)			
Declared cooling capacity	P_D	7.27	kW
Declared power input	D_D	1.49	kW
Rated COP	COP_D	4.87	
Parameters at full load and ambient temperature 43°C (where applicable)			
Cooling capacity	P_3	4.16	kW
Power input	D_3	3.18	kW
Declared COP	COP_3	1.31	
Other items			
Capacity control	Fixed		
Degradation coefficient for fixed and staged capacity units	Cdc	0.25	
Contact details	TEV LIMITED Unit 4 Armytage Road Brighouse HD6 1QF		

Model(s): MRC (+) 90 S/P			
Refrigerant fluid(s): R404A			
Item	Symbol	Value	Unit
Evaporating temperature	t	-10°C	°C
Annual electricity consumption	Q	10875	kWh/a
Seasonal energy performance ratio	$SEPR$	3.64	
Parameters at full load and ambient temperature 32°C (Point A)			
Rated cooling capacity	P_A	6.380	kW
Rated power input	D_A	2.920	kW
Rated COP	COP_A	2.18	
Parameters at part load and ambient temperature 25°C (Point B)			
Declared cooling capacity	P_B	6.81	kW
Declared power input	D_B	2.53	kW
Rated COP	COP_B	2.70	
Parameters at part load and ambient temperature 15°C (Point C)			
Declared cooling capacity	P_C	7.92	kW
Declared power input	D_C	1.95	kW
Rated COP	COP_C	4.06	
Parameters at part load and ambient temperature 5°C (Point D)			
Declared cooling capacity	P_D	8.48	kW
Declared power input	D_D	1.68	kW
Rated COP	COP_D	5.04	
Parameters at full load and ambient temperature 43°C (where applicable)			
Cooling capacity	P_3	4.86	kW
Power input	D_3	3.68	kW
Declared COP	COP_3	1.32	
Other items			
Capacity control	Fixed		
Degradation coefficient for fixed and staged capacity units	Cdc	0.25	
Contact details	TEV LIMITED Unit 4 Armytage Road Brighouse HD6 1QF		

Model(s): MRC (+) 100 S/P			
Refrigerant fluid(s): R404A			
Item	Symbol	Value	Unit
Evaporating temperature	t	-10°C	°C
Annual electricity consumption	Q	14438	kWh/a
Seasonal energy performance ratio	$SEPR$	3.01	
Parameters at full load and ambient temperature 32°C (Point A)			
Rated cooling capacity	P_A	7.060	kW
Rated power input	D_A	3.730	kW
Rated COP	COP_A	1.89	
Parameters at part load and ambient temperature 25°C (Point B)			
Declared cooling capacity	P_B	7.54	kW
Declared power input	D_B	3.37	kW
Rated COP	COP_B	2.24	
Parameters at part load and ambient temperature 15°C (Point C)			
Declared cooling capacity	P_C	9.05	kW
Declared power input	D_C	2.70	kW
Rated COP	COP_C	3.35	
Parameters at part load and ambient temperature 5°C (Point D)			
Declared cooling capacity	P_D	9.69	kW
Declared power input	D_D	2.32	kW
Rated COP	COP_D	4.19	
Parameters at full load and ambient temperature 43°C (where applicable)			
Cooling capacity	P_3	5.38	kW
Power input	D_3	4.71	kW
Declared COP	COP_3	1.14	
Other items			
Capacity control	Fixed		
Degradation coefficient for fixed and staged capacity units	Cdc	0.25	
Contact details	TEV LIMITED Unit 4 Armytage Road Brighouse HD6 1QF		

Model(s): MRC (+) 150 S/P			
Refrigerant fluid(s): R404A			
Item	Symbol	Value	Unit
Evaporating temperature	t	-10°C	°C
Annual electricity consumption	Q	15601	kWh/a
Seasonal energy performance ratio	$SEPR$	3.48	
Parameters at full load and ambient temperature 32°C (Point A)			
Rated cooling capacity	P_A	8.830	kW
Rated power input	D_A	4.290	kW
Rated COP	COP_A	2.06	
Parameters at part load and ambient temperature 25°C (Point B)			
Declared cooling capacity	P_B	9.43	kW
Declared power input	D_B	3.84	kW
Rated COP	COP_B	2.46	
Parameters at part load and ambient temperature 15°C (Point C)			
Declared cooling capacity	P_C	11.32	kW
Declared power input	D_C	2.87	kW
Rated COP	COP_C	3.94	
Parameters at part load and ambient temperature 5°C (Point D)			
Declared cooling capacity	P_D	12.11	kW
Declared power input	D_D	2.46	kW
Rated COP	COP_D	4.92	
Parameters at full load and ambient temperature 43°C (where applicable)			
Cooling capacity	P_3	6.73	kW
Power input	D_3	5.41	kW
Declared COP	COP_3	1.24	
Other items			
Capacity control	Fixed		
Degradation coefficient for fixed and staged capacity units	Cdc	0.25	
Contact details	TEV LIMITED Unit 4 Armytage Road Brighouse HD6 1QF		

Model(s): MRC (+) 80 3/P			
Refrigerant fluid(s): R404A			
Item	Symbol	Value	Unit
Evaporating temperature	t	-10°C	°C
Annual electricity consumption	Q	9517	kWh/a
Seasonal energy performance ratio	$SEPR$	3.53	
Parameters at full load and ambient temperature 32°C (Point A)			
Rated cooling capacity	P_A	5.460	kW
Rated power input	D_A	2.520	kW
Rated COP	COP_A	2.17	
Parameters at part load and ambient temperature 25°C (Point B)			
Declared cooling capacity	P_B	5.83	kW
Declared power input	D_B	2.21	kW
Rated COP	COP_B	2.64	
Parameters at part load and ambient temperature 15°C (Point C)			
Declared cooling capacity	P_C	6.79	kW
Declared power input	D_C	1.73	kW
Rated COP	COP_C	3.93	
Parameters at part load and ambient temperature 5°C (Point D)			
Declared cooling capacity	P_D	7.27	kW
Declared power input	D_D	1.49	kW
Rated COP	COP_D	4.87	
Parameters at full load and ambient temperature 43°C (where applicable)			
Cooling capacity	P_3	4.16	kW
Power input	D_3	3.16	kW
Declared COP	COP_3	1.31	
Other items			
Capacity control	Fixed		
Degradation coefficient for fixed and staged capacity units	Cdc	0.25	
Contact details	TEV LIMITED Unit 4 Amytage Road Brighouse HD6 1QF		

Model(s): MRC (+) 80 3/P			
Refrigerant fluid(s): R404A			
Item	Symbol	Value	Unit
Evaporating temperature	t	-10°C	°C
Annual electricity consumption	Q	10875	kWh/a
Seasonal energy performance ratio	$SEPR$	3.64	
Parameters at full load and ambient temperature 32°C (Point A)			
Rated cooling capacity	P_A	6.380	kW
Rated power input	D_A	2.920	kW
Rated COP	COP_A	2.18	
Parameters at part load and ambient temperature 25°C (Point B)			
Declared cooling capacity	P_B	6.81	kW
Declared power input	D_B	2.53	kW
Rated COP	COP_B	2.70	
Parameters at part load and ambient temperature 15°C (Point C)			
Declared cooling capacity	P_C	7.92	kW
Declared power input	D_C	1.95	kW
Rated COP	COP_C	4.06	
Parameters at part load and ambient temperature 5°C (Point D)			
Declared cooling capacity	P_D	8.48	kW
Declared power input	D_D	1.68	kW
Rated COP	COP_D	5.04	
Parameters at full load and ambient temperature 43°C (where applicable)			
Cooling capacity	P_3	4.86	kW
Power input	D_3	3.68	kW
Declared COP	COP_3	1.32	
Other items			
Capacity control	Fixed		
Degradation coefficient for fixed and staged capacity units	Cdc	0.25	
Contact details	TEV LIMITED Unit 4 Amytage Road Brighouse HD6 1QF		

Model(s): MRC (+) 100 3/P			
Refrigerant fluid(s): R404A			
Item	Symbol	Value	Unit
Evaporating temperature	<i>t</i>	-10°C	°C
Annual electricity consumption	<i>Q</i>	14438	kWh/a
Seasonal energy performance ratio	<i>SEPR</i>	3.01	
Parameters at full load and ambient temperature 32°C (Point A)			
Rated cooling capacity	<i>P_A</i>	7.060	kW
Rated power input	<i>D_A</i>	3.730	kW
Rated COP	<i>COP_A</i>	1.89	
Parameters at part load and ambient temperature 25°C (Point B)			
Declared cooling capacity	<i>P_B</i>	7.54	kW
Declared power input	<i>D_B</i>	3.37	kW
Rated COP	<i>COP_B</i>	2.24	
Parameters at part load and ambient temperature 15°C (Point C)			
Declared cooling capacity	<i>P_C</i>	9.05	kW
Declared power input	<i>D_C</i>	2.70	kW
Rated COP	<i>COP_C</i>	3.35	
Parameters at part load and ambient temperature 5°C (Point D)			
Declared cooling capacity	<i>P_D</i>	9.89	kW
Declared power input	<i>D_D</i>	2.32	kW
Rated COP	<i>COP_D</i>	4.19	
Parameters at full load and ambient temperature 43°C (where applicable)			
Cooling capacity	<i>P₃</i>	5.38	kW
Power input	<i>D₃</i>	4.71	kW
Declared COP	<i>COP₃</i>	1.14	
Other items			
Capacity control	Fixed		
Degradation coefficient for fixed and staged capacity units	<i>C_{dc}</i>	0.25	
Contact details	TEV LIMITED Unit 4 Armytage Road Brighouse HD6 1QF		

Model(s): MRC (+) 130 3/P			
Refrigerant fluid(s): R404A			
Item	Symbol	Value	Unit
Evaporating temperature	<i>t</i>	-10°C	°C
Annual electricity consumption	<i>Q</i>	15789	kWh/a
Seasonal energy performance ratio	<i>SEPR</i>	3.15	
Parameters at full load and ambient temperature 32°C (Point A)			
Rated cooling capacity	<i>P_A</i>	8.090	kW
Rated power input	<i>D_A</i>	4.240	kW
Rated COP	<i>COP_A</i>	1.91	
Parameters at part load and ambient temperature 25°C (Point B)			
Declared cooling capacity	<i>P_B</i>	8.64	kW
Declared power input	<i>D_B</i>	3.85	kW
Rated COP	<i>COP_B</i>	2.24	
Parameters at part load and ambient temperature 15°C (Point C)			
Declared cooling capacity	<i>P_C</i>	10.37	kW
Declared power input	<i>D_C</i>	2.92	kW
Rated COP	<i>COP_C</i>	3.56	
Parameters at part load and ambient temperature 5°C (Point D)			
Declared cooling capacity	<i>P_D</i>	11.10	kW
Declared power input	<i>D_D</i>	2.50	kW
Rated COP	<i>COP_D</i>	4.44	
Parameters at full load and ambient temperature 43°C (where applicable)			
Cooling capacity	<i>P₃</i>	6.17	kW
Power input	<i>D₃</i>	5.35	kW
Declared COP	<i>COP₃</i>	1.15	
Other items			
Capacity control	Fixed		
Degradation coefficient for fixed and staged capacity units	<i>C_{dc}</i>	0.25	
Contact details	TEV LIMITED Unit 4 Armytage Road Brighouse HD6 1QF		

Model(s): MRC (+) 150 3P			
Refrigerant fluid(s): R404A			
Item	Symbol	Value	Unit
Evaporating temperature	t	-10°C	°C
Annual electricity consumption	Q	15601	kWh/a
Seasonal energy performance ratio	$SEPR$	3.48	
Parameters at full load and ambient temperature 32°C (Point A)			
Rated cooling capacity	P_A	6.830	kW
Rated power input	D_A	4.290	kW
Rated COP	COP_A	2.06	
Parameters at part load and ambient temperature 25°C (Point B)			
Declared cooling capacity	P_B	9.43	kW
Declared power input	D_B	3.84	kW
Rated COP	COP_B	2.46	
Parameters at part load and ambient temperature 15°C (Point C)			
Declared cooling capacity	P_C	11.32	kW
Declared power input	D_C	2.87	kW
Rated COP	COP_C	3.94	
Parameters at part load and ambient temperature 5°C (Point D)			
Declared cooling capacity	P_D	12.11	kW
Declared power input	D_D	2.48	kW
Rated COP	COP_D	4.92	
Parameters at full load and ambient temperature 43°C (where applicable)			
Cooling capacity	P_3	6.73	kW
Power input	D_3	5.41	kW
Declared COP	COP_3	1.24	
Other items			
Capacity control	Fixed		
Degradation coefficient for fixed and staged capacity units	Cdc	0.25	
Contact details	TEV LIMITED Unit 4 Armytage Road Brighouse HD6 1QF		

Model(s): MRC (+) 165 3P			
Refrigerant fluid(s): R404A			
Item	Symbol	Value	Unit
Evaporating temperature	t	-10°C	°C
Annual electricity consumption	Q	18664	kWh/a
Seasonal energy performance ratio	$SEPR$	3.47	
Parameters at full load and ambient temperature 32°C (Point A)			
Rated cooling capacity	P_A	10.530	kW
Rated power input	D_A	5.020	kW
Rated COP	COP_A	2.10	
Parameters at part load and ambient temperature 25°C (Point B)			
Declared cooling capacity	P_B	11.24	kW
Declared power input	D_B	4.54	kW
Rated COP	COP_B	2.48	
Parameters at part load and ambient temperature 15°C (Point C)			
Declared cooling capacity	P_C	13.50	kW
Declared power input	D_C	3.45	kW
Rated COP	COP_C	3.91	
Parameters at part load and ambient temperature 5°C (Point D)			
Declared cooling capacity	P_D	14.44	kW
Declared power input	D_D	2.95	kW
Rated COP	COP_D	4.89	
Parameters at full load and ambient temperature 43°C (where applicable)			
Cooling capacity	P_3	8.03	kW
Power input	D_3	6.33	kW
Declared COP	COP_3	1.27	
Other items			
Capacity control	Fixed		
Degradation coefficient for fixed and staged capacity units	Cdc	0.25	
Contact details	TEV LIMITED Unit 4 Armytage Road Brighouse HD6 1QF		

Model(s): MRC (+) 180 3/P			
Refrigerant fluid(s): R404A			
Item	Symbol	Value	Unit
Evaporating temperature	t	-10°C	°C
Annual electricity consumption	Q	20094	kWh/a
Seasonal energy performance ratio	$SEPR$	3.56	
Parameters at full load and ambient temperature 32°C (Point A)			
Rated cooling capacity	PA	11.640	kW
Rated power input	DA	5.520	kW
Rated COP	$COPA$	2.11	
Parameters at part load and ambient temperature 25°C (Point B)			
Declared cooling capacity	PB	12.43	kW
Declared power input	DB	4.92	kW
Rated COP	$COPB$	2.53	
Parameters at part load and ambient temperature 15°C (Point C)			
Declared cooling capacity	PC	14.92	kW
Declared power input	DC	3.71	kW
Rated COP	$COPC$	4.02	
Parameters at part load and ambient temperature 5°C (Point D)			
Declared cooling capacity	PD	15.97	kW
Declared power input	DD	3.17	kW
Rated COP	$COPD$	5.04	
Parameters at full load and ambient temperature 43°C (where applicable)			
Cooling capacity	$P3$	8.88	kW
Power input	$D3$	6.96	kW
Declared COP	$COP3$	1.27	
Other items			
Capacity control	Fixed		
Degradation coefficient for fixed and staged capacity units	Cdc	0.25	
Contact details	TEV LIMITED Unit 4 Armytage Road Brighouse HD6 1QF		

COMPONENT IDENTIFICATION

MRC+ 15 - 100

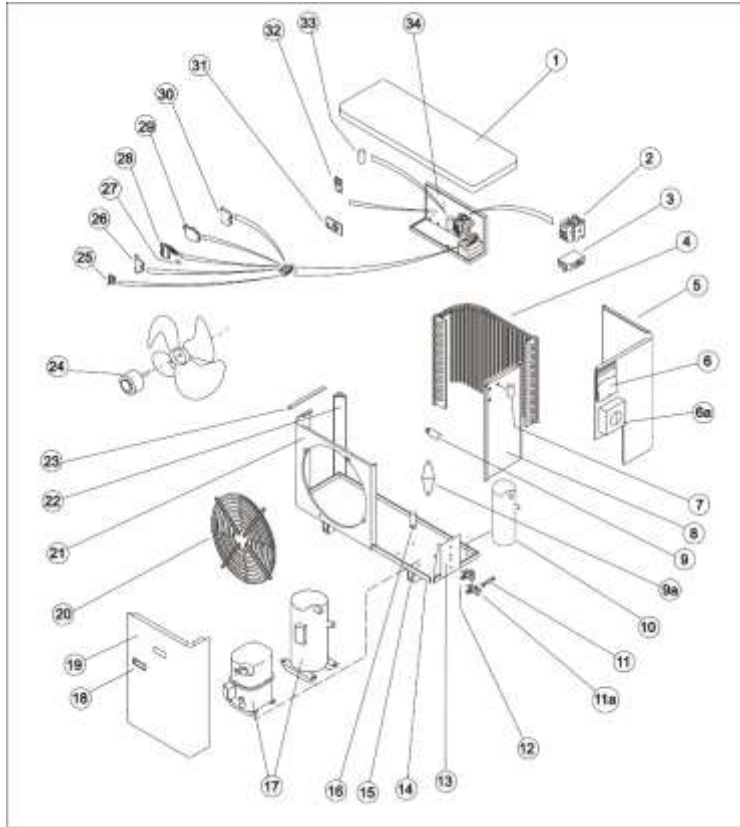

1	LID	17	COMPRESSOR
2	CONTACTOR	18	HANDLE
3	OVERLOAD	19	FRONT ACCESS
4	HEAT EXCHANGER COIL	20	FAN GUARD
5	REAR ACCESS PANEL	21	FASCIA PANEL
6	MAINS TERMINAL COVER	22	CORNER PANEL
6a	ISOLATOR	23	SUPPORT BRACKET
7	FAN CAPACITOR	24	FAN / MOTOR ASSEMBLY
8	BULKHEAD PANEL	25	END CLAMP
9	HP SWITCH (MANUAL, OPTION)	26	TERMINAL
9a	DRIER	27	FUSE
10	RECEIVER	28	FUSE TERMINAL
11	SIGHT GLASS	29	TERMINAL (4 WAY)
11a	SERVICE VALVE (LIQUID)	30	EARTH TERMINAL
12	SERVICE VALVE (SUCTION)	31	HEAD PRESSURE CONTROL pcb
13	VALVE PANEL	32	3 MINUTE TIMER pcb
14	BASE	33	COMPRESSOR CAPACITOR
15	MOUNTING FOOT	34	ELECTRICS BOX
16	LP SWITCH		

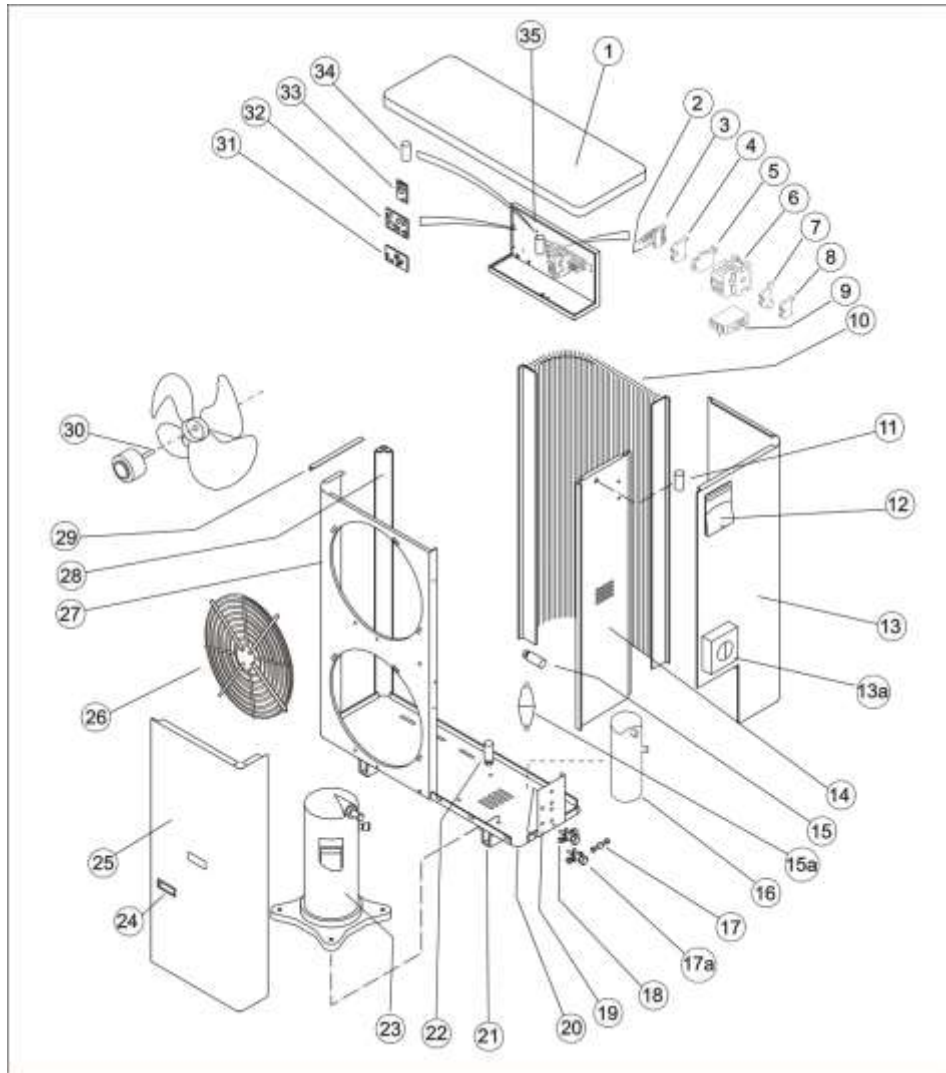

1	LID	17a	SERVICE VALVE (LIQUID)
2	FUSE TERMINAL	18	SERVICE VALVE (SUCTION)
3	FUSE	19	VALVE PANEL
4	TERMINAL	20	BASE
5	TERMINAL (4 WAY)	21	MOUNTING FOOT
6	CONTACTOR	22	LP SWITCH
7	EARTH TERMINAL	23	COMPRESSOR
8	END CLAMP	24	HANDLE
9	OVERLOAD	25	FRONT ACCESS PANEL
10	HEAT EXCHANGER COIL	26	FAN GUARD
11	FAN CAPACITOR	27	FASCIA PANEL
12	MAINS TERMINAL COVER	28	CORNER PANEL
13	REAR ACCESS PANEL	29	SUPPORT BRACKET
13a	ISOLATOR	30	FAN / MOTOR ASSEMBLY
14	BULKHEAD PANEL	31	HEAD PRESSURE CONTROL pcb
15	HP SWITCH (MANUAL, OPTION)	32	POWER BOARD
15a	DRIER	33	3 MINUTE TIMER pcb
16	RECEIVER	34	COMPRESSOR CAPACITOR
17	SIGHT GLASS	35	ELECTRICS BOX